

NECEPT

Northeast **C**enter of **E**xcellence for
Pavement **T**echnology

Certified Asphalt Field Technician Update/Refresher Course

2022

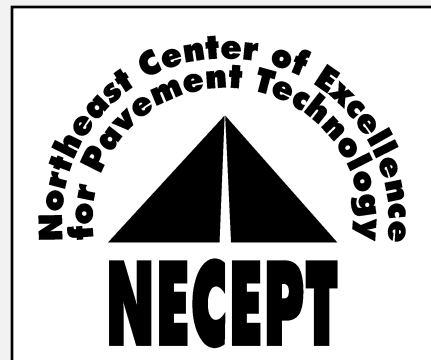

NECEPT

Website: www.superpave.psu.edu

Email: superpave@psu.edu

Covers PENNDOT Certification Program

Click on Training to Access Course Information:

Courses, Registration, Schedule & Agenda, Pub 351, FAQ

Program Assistant

(814-863-1293)



Housekeeping

- 1. Work Experience Requirements**
- 2. Attendance and Participation**
- 3. Breaks during the Course**
- 4. Quiz at the end of each Module**
- 5. Course Material**
- 6. Videos**
- 7. Course Objective**
- 8. Course Agenda**

1. Work Experience Requirements for Certification Renewal (See Pub 351)

- **Minimum of 500 hours of documented experience in asphalt mixture paving or paving inspection since date of last certification.**
- **Type of Experience:**
 - asphalt mixture paving
 - QC or QA inspection experience
 - Surface preparation before asphalt mixture paving
 - asphalt mixture paving, compaction, ride quality measurement
 - analysis, longitudinal joint density measurement or analysis
- **Source of Experience:**
 - PennDOT ECMS, and maintenance,
 - HOP, EMA projects, PTC construction or maintenance projects,
 - Pennsylvania municipal government projects which used PennDOT Liquid Fuels Funds,
 - or from projects in other State DOTs participating in MARTCP.”

2. Attendance and Participation

- Attendance in the course is required.
- Participants' Videos will be off.
- Participants' microphones will be off.
- Have your speakers ON.
- Questions can be asked through Zoom.

3. Breaks during the Course

- **Breaks: Short Breaks (5 to 10 minutes)**
- **Breaks at the End of each Module (after quiz)**

4. Quiz at the end of each module

- Short Quiz – Self Graded
- 5 to 10 Questions
- 4 to 6 minutes
- **REQUIRED for Online Course Only:**
 - **Must answer 85 percent of questions**
 - **Not graded for correct or wrong answers**

NOTE: At the end of the module, take the quiz first before taking a break.
The quiz time is limited and will not be reopened.

5. Course Material

Course Material:

**is available online at the NECEPT
Website (superpave.psu.edu)**

Go to Training/Asphalt/Asphalt Field

Link below:

<https://www.superpave.psu.edu/Training/Asphalt/Asphalt-Field.aspx>

6. Videos

- **There are four videos for this course:**
 - **LTS Testing (21 min.)**
 - **Surface Preparation (13 min.)**
 - **Longitudinal Joint Construction (12.5 min.)**
 - **Asphalt Laydown (13 min.)**

We will show the first three during the relevant modules but those having trouble viewing through ZoomTM, could directly watch at the links provided.

7. Course Objectives

- This is an ***update/refresher*** course for **renewal** of certification as an Asphalt Field Technician. This course provides credit toward renewal of certification for participants.
- **The course objectives are**
 - To provide an ***update*** of essential PennDOT Specifications and PTMs
 - To provide a ***review*** of operations and procedures for asphalt paving
 - To present the latest hot topics and issues related to asphalt materials and paving

8. Course Agenda

- **Module 1– Field Technician Responsibilities**
- **Module 2– Update on PennDOT Specifications
(Parts 1 and 2)**
- **Module 3– LTS Testing (Video)**
- **Module 4– Update on PWL**
- **Module 5– Review of Superpave & JMF Nomenclature**
- **Module 6- Lots & Sublots Layout and Sample Locations**
- **Module 7– Review of PTMs**

- **Problem Solving**
- **Open Discussion, Questions, Areas of Concern**

ACRONYMS

- **Make sure you get familiar with these terms as many of them are frequently used in everyday practice of production and construction of asphalt mixes.**

ACRONYMS

AASHTO	HMA	NMAS	RAM
ACE	IRI	OSHA	RAP
AET	JMF	PAPA	RAS
AI	LTS	PG	SRL
ATPBC	MTV	PTM	SMA
ASTM	MUTCD	QC/QA	TAC
ESAL	NAPA	RPS	VMA
FHWA	NECEPT	PWT	WMA

Excellent Resource

- Hot-Mix Asphalt Paving Handbook
2000 (July 2001)
- Available from NAPA*
Online Store
 - List Price: \$12
 - 231 Pages
 - 65 MB

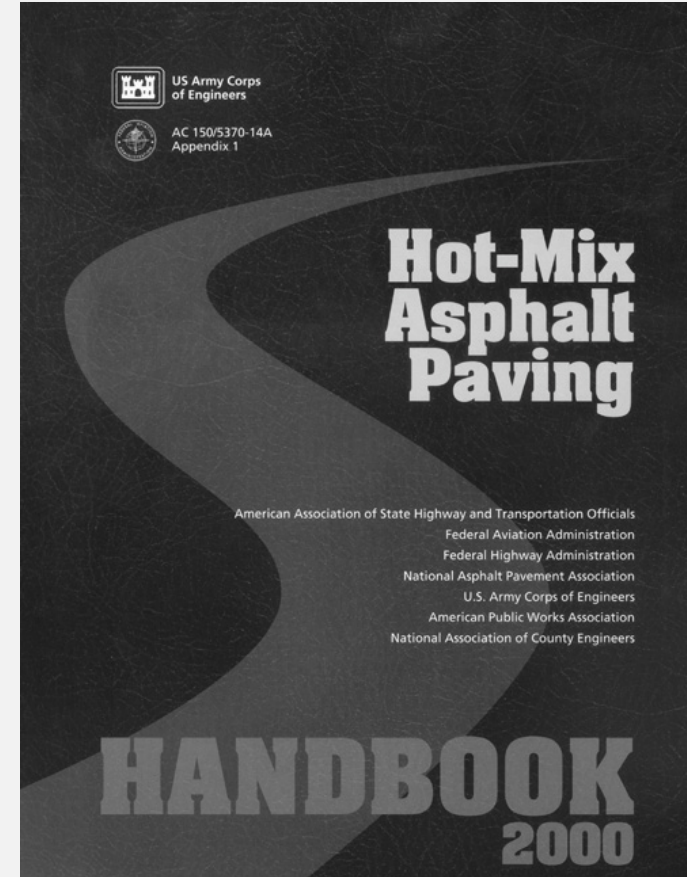

<https://member.asphaltpavement.org/Shop/Product-Catalog/Product-Details?productid={47A571B7-7701-EA11-A811-000D3A4DBF2F}>

*National Asphalt Pavement Association

Excellent Resource

- **A Guide for Hot Mix Asphalt Pavement CD-ROM**
- **Available from NAPA* Online Store, \$32**

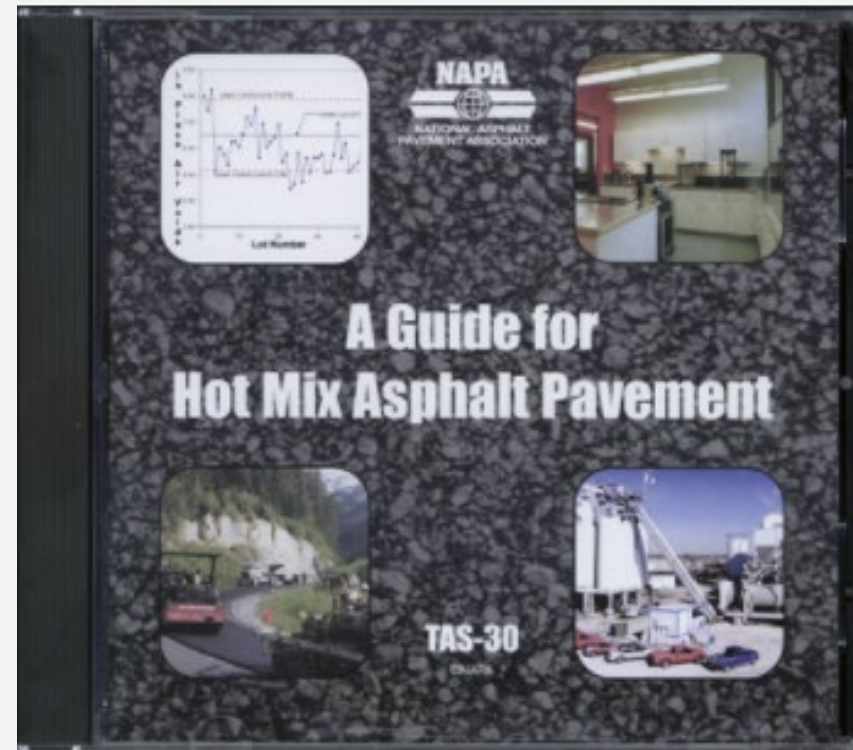

- <https://member.asphaltpavement.org/Shop/Product-Catalog/Product-Details?productid=%7BA9A571B7-7701-EA11-A811-000D3A4DBF2F%7D>

***National Asphalt Pavement Association**

Excellent Resource

Pennsylvania Asphalt Pavement Association

Constructing Quality Hot- Mix Pavements in Pennsylvania Checklist

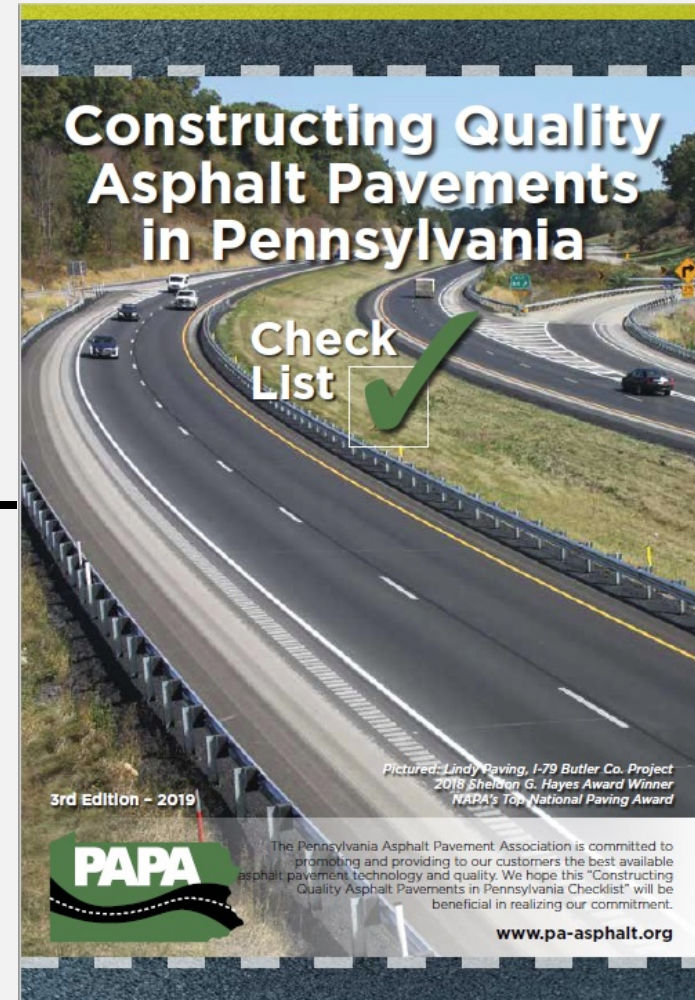

<http://www.pa-asphalt.org/>

Excellent Resource

- **Warm-Mix Asphalt: Contractor's Experiences (July 2008)**
- **Available from NAPA***
Online Store
 - List Price: \$20
 - Gov't/Ed: \$15
 - Members: Free

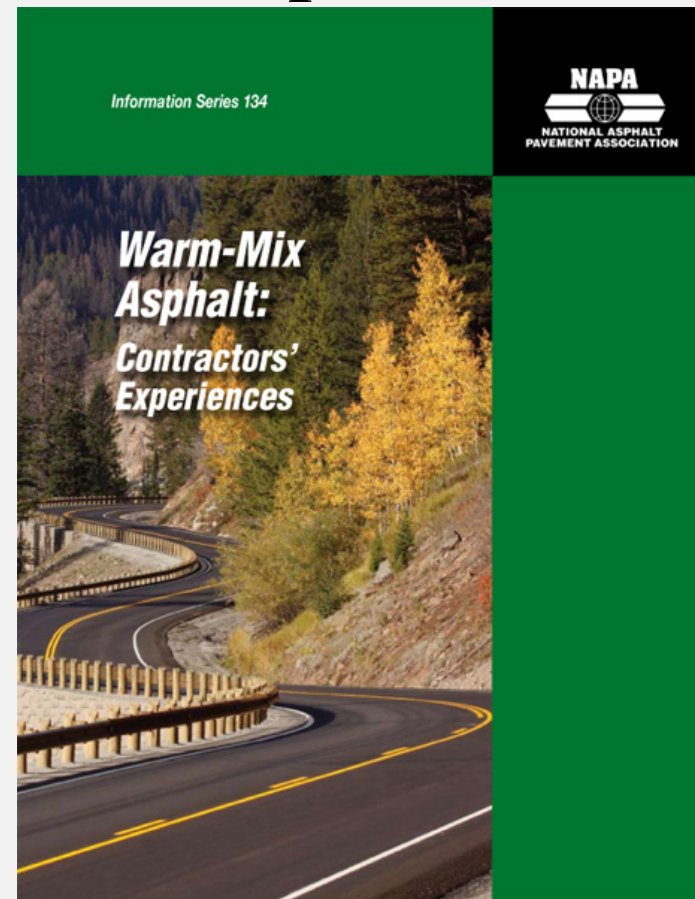

<https://store.asphaltpavement.org/index.php?productID=630>

*National Asphalt Pavement Association

Excellent Resource

- **Warm-Mix Asphalt: Best Practices (January 2012)**
- **Available from NAPA*
Online Store**
 - List Price: \$45
 - Gov't/Ed: \$35
 - Members: \$25

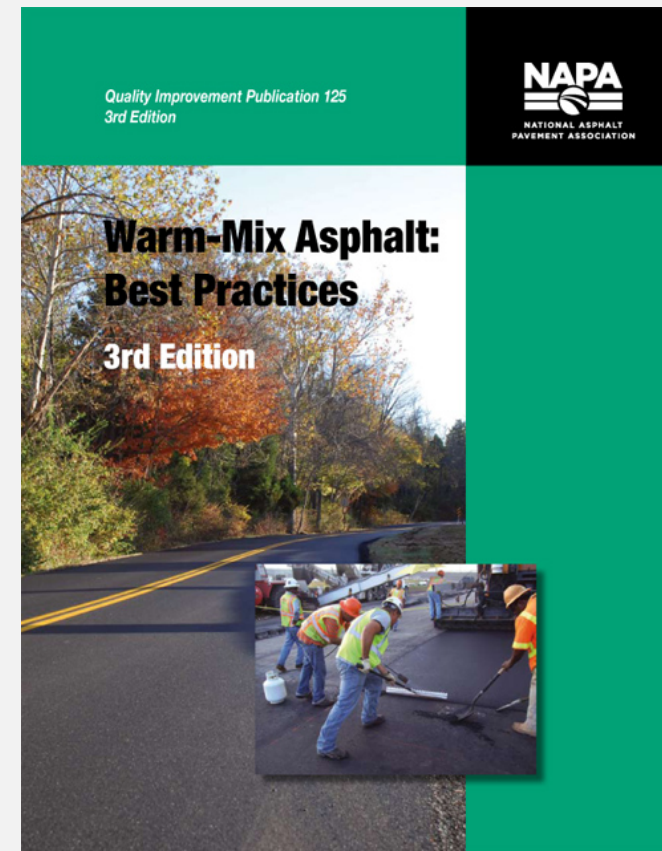

<https://member.asphaltpavement.org/Shop/Product-Catalog/Product-Details?productid={79A571B7-7701-EA11-A811-000D3A4DBF2F}>

***National Asphalt Pavement Association**

Excellent Resource

Pennsylvania Asphalt Pavement Association

Constructing Quality Hot-Mix Pavements in Pennsylvania Checklist

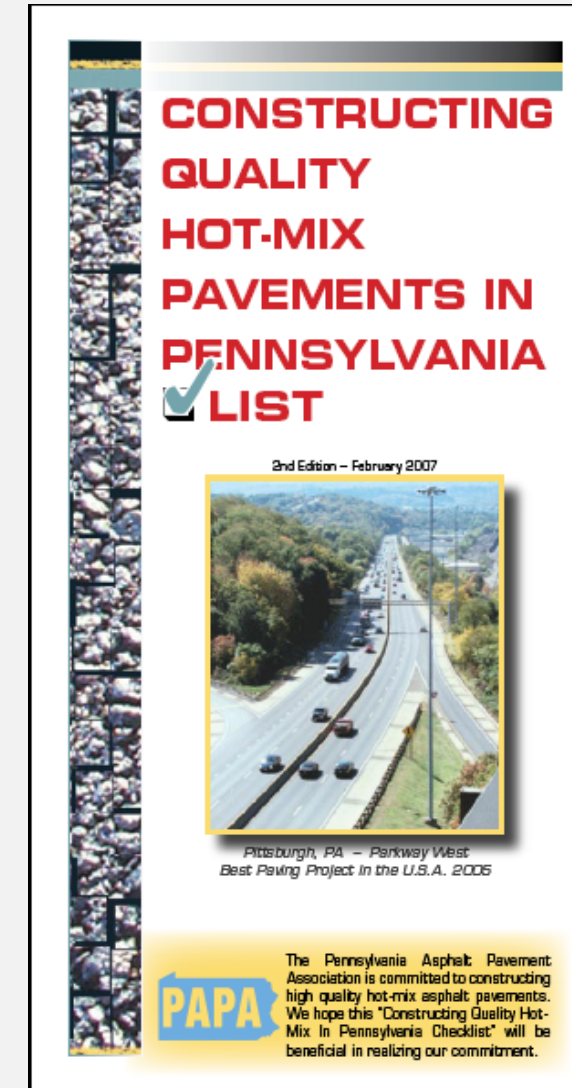

Review of Field Technician's Responsibilities

Technician Certification Program

- **PennDOT Pub 351**
 - 23 CFR
 - Background Info
 - Certification & Recertification Requirements
 - Application Procedures
 - Exam Review & Retest
 - Code of Ethics

**BITUMINOUS OR ASPHALT
TECHNICIAN CERTIFICATION
PROGRAM**

**BITUMINOUS OR ASPHALT
PLANT AND FIELD TECHNICIANS**

Initial Certification Requirements
Certification Renewal Requirements
Registration Procedures
Performance Review and Code of Ethics
Course Administration

11/2018



pennsylvania
DEPARTMENT OF TRANSPORTATION
www.penndot.gov

PUB 351 (11-18)

Asphalt Technician in Training

NEW requirements will affect YOU

- Field Supervisor will need to sign off on experience (24 hours)
- ACE will need to sign off on capabilities.
- Must take Review and Certification Course in next Cycle (Passing Grade)

Certification Renewal

Pub 351: Section IX

- **Must be Certified for previous 5 years**
- **Must have 500 documented hours experience on State Asphalt Paving projects**
- **Must have PennDOT or PTC signature to confirm satisfactory performance**
- **Within the 5 years, must have attended :**
 - **2 NECEPT Field Technician Update/Refresher Courses, or....**
 - **1 NECEPT Update/Refresher Course and 1 acceptable asphalt-related conference, seminar, or workshop**



Certification Renewal

Acceptable Asphalt-Related Annual Conference Seminars, or Workshops

- Annual APC Conferences
- Annual PAPA Conferences
- Mid-Atlantic States Quality Assurance Workshop
- Nationally recognized conferences or courses
- PennDOT pre-approved Department or Industry sponsored training



Certification Renewal

Submit:

- **Recertification Application**
- **With Processing Fee (\$35.00)**

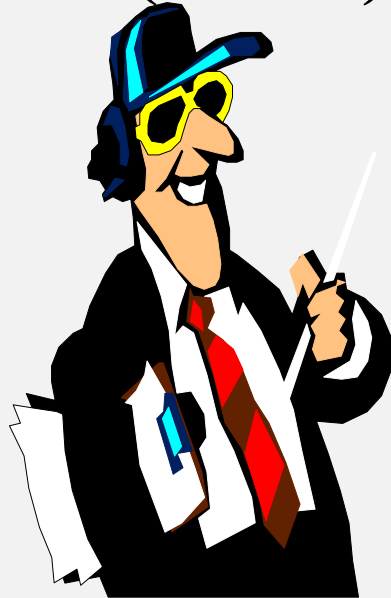

www.superpave.psu.edu



NECEPT

**PENNDOT BITUMINOUS CERTIFICATION RENEWAL
OR BITUMINOUS LEVEL 2 PLANT
INITIAL CERTIFICATION (CARDS ONLY)
2019 APPLICATION FORM**

BEFORE YOU FILL OUT THIS FORM, READ THE PRECEEDING PAGE

♦ Enter your 2-6 Digit NECEPT ID number here _____

♦ If you do not know your ID number, call (814) 863-1293. Do not submit this application without your ID number.

REFER TO PENNDOT PUB. 351 FOR REQUIREMENTS FOR INITIAL CERTIFICATION & CERTIFICATION RENEWAL

APPLICATION CATEGORIES:

	FEE
Bituminous Field Technician Certification Renewal Card Current Expiration Date of Bituminous Field Tech Certification: _____	\$35.00
Bituminous Level 1 Plant Technician Certification Renewal Card Current Expiration Date of Bituminous Level 1 Plant Tech Certification: _____	\$35.00
Bituminous Level 2 Plant Technician Certification Renewal Card Current Expiration Date of Bituminous Level 2 Plant Tech Certification: _____	\$35.00

If this is your initial time applying for Level 2 Plant, please indicate date when you completed the Superpave Mix Design Workshop _____

Applicant Name: _____

Email Address(es): *YOU MUST ENTER AT LEAST ONE EMAIL ADDRESS TO RECEIVE CONFIRMATION EMAILS.*
1 _____ 2 _____

Affiliation: PennDOT (District/Bureau) _____ Industry _____ Consultant _____ Other _____

Employer: _____ **Job Title:** _____

Mailing Address: _____ **City:** _____ **State & Zip:** _____

Daytime Phone: _____ **Alternate Phone:** _____ **Fax Number:** _____

Work Experience: Minimum 500 hours for all renewals, 1,000 hours for initial. (If insufficient space below, attach separate sheet(s).)

Start Date	End Date	Work Performed (List Projects/Total Hours/Location/Immediate Supervisor and Supervisor's phone #)

Learning Activities: Must include minimum of two Update/Refresher Courses in two separate years OR one Update/Refresher Course plus one additional learning activity listed in Pub. 351 or pre-approved by your DME/DMM. If you are applying for INITIAL certification of Level 2 Plant, this is not required.

Date	Location	Name of Activity

SIGNATURES REQUIRED BEFORE SUBMISSION TO NECEPT:

Supervisor Name _____ Supervisor Signature _____

PennDOT ACE/M, DME/M Name* _____ PennDOT ACE/M, DME/M Signature* _____

*May be a PennDOT Bureau Representative or a PTC Representative Name and Signature as indicated in Pub. 351.

BEFORE MAILING THIS FORM, PLEASE MAKE SURE YOU HAVE COMPLETED THE FOLLOWING:

- ♦ Fill in the form completely, including obtaining signatures.
- ♦ Enclose any necessary documents, including proof of attendance to learning activities, if applicable.
- ♦ Enclose payment.

Incomplete applications will be returned!



Section XIII: Code of Ethics

Four Principles:

- a. Demonstrate a concern for the welfare and dignity of the recipients of the services, including Department personnel.
- b. Maintain high standards of professional competence.
- c. Provide accurate information about asphalt technician services.
- d. Function with discretion and integrity in relations with colleagues and other professionals.



As a certified Technician, you may represent one of the following:



In any case, your responsibility is to ensure a quality product is being placed.

What are your responsibilities ?



1. Know the specifications
2. Know the PTMs needed to ensure quality control
3. Be familiar with paving operations
4. Recognize mix and paving deficiencies
5. Be able to recommend corrective action
6. Adhere to the four principals of the code of ethics

Responsibilities: Pre-Pave Set Up

- Review Job Mix Formula
- Review Project Quality Control Plan & Special Provisions
- Ensure proper preparation of the Nuclear Gauge or Electrical Impedance Gauge
- Check Compaction Equipment
- Set Up Initial Rolling Pattern
- Check Box Sample and/or Core Locations

Responsibilities: Start of Paving Operation

- Check surface preparation
- Check Mix Temperature
- Record Initial Density Readings
- Check Mat Temperature
- Check Mat Appearance
- Check Joints
- Make Adjustments as Required
- Record Initial Roller Pattern/ Temps

Responsibilities: Paving Operation

- Monitor Startup Operations
- Monitor Truck Exchange
- Monitor Compaction
- Check with Plant
- Check Finished Product
- Specify Coring Locations for Acceptance
- Maintain Good Communications.

Experience

- **Experience allows you to recognize a mistake when you make it again.**
- **Keep records of mix tendencies as to temperature, amplitude, vibration, cross-slope and grade as related to density and ride.**

**Your Effort Towards Achieving
A Quality Paving Job Makes
The Difference Between A Great
Job And A Mediocre One.**

MAKE THE EFFORT!

N
E
C
E
P
T

Asphalt Construction Program Certified Asphalt Field Technician

An Update on PennDOT Specifications (Part 1)



PennDOT Specifications

Which Specifications Are Most Significant?

The specifications that cover your project and affect YOU are the most important. Be aware of the effective change dates and your project let date.

What you need to know...

- **PennDOT Specifications Publication 408:**
- **Sections covering Asphalt & the important aspects of these specifications**
- **PennDOT website:**
www.penndot.gov/



PennDOT Specifications (Publication 408)

**Pub 408/2020:
Initial Edition (IE)**
(Effective April 10, 2020)



PennDOT Specifications (Publication 408)

Version	Effective Date
Initial Edition	April 10, 2020
Change No. 1	October 2, 2020
Change No. 2	April 9, 2021
Change No. 3	October 8, 2021
Change No. 4	April 1, 2022
Change No. 5	October 7, 2022
Change No. 6	April 14, 2023
Change No. 7	October 6, 2023

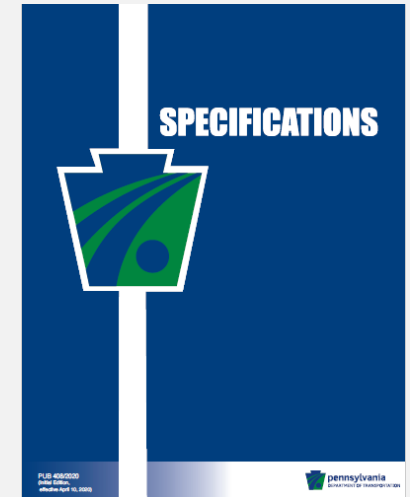

2020

Relevant Sections Added in Pub 408 Since October 2016:

Date	Section	Description
October 2016	420	Pervious Asphalt Pavement System
October 2016	489	Ultra-Thin Bonded Wearing Course
April 2018	412	6.3-mm Thin Asphalt Overlay
April 2020	313	Plant Produced Asphalt Mixes (base course) – Merging 309 and 311
April 2020	413	Plant Produced Asphalt Mixes (wearing and binder courses) – Merging 409 and 411
April 2022	314	Rich Base Courses* (CT: H-21-017)

* Rich Base Course will be included in Change No. 4 of 408 Spec (2020 Edition) in April 2022

Relevant Sections Removed from Pub 408 within the Last 5 Years:

Date	Section	Description
October 2017	422/430/431 /439/440	Removal of FJ & FB mixtures for wearing and binder courses
April 2020	309	SP Asphalt Mixtures, HMA Base Course – Merged into 313.
April 2020	311	SP Asphalt Mixture, Warm Base Course – Merged into 313.
April 2020	320	Aggregate-Bituminous Base Course.
April 2020	409	SP Asphalt Mixtures, HMA wearing and binder courses – Merged into 413.
April 2020	411	SP Asphalt Mixtures, WMA wearing and binder courses – Merged into 413.

Major Asphalt Related Changes in Pub 408 Since April 2017

Date	Section	Description
April 2017	411 (Now 413)	Use of Anti-strip Additive
October 2017	409 (Now 413)	Adding VMA Requirements for 4.75-mm Mixture
October 2017	419	Allowing Use of WMA in SMA
October 2017	460	New Tack with half of AET Water, and inclusion of non-tracking tacks, and revision of application rates.
October 2018	483	Emulsion class changed from CSS-1hPM to CQS-1hPM.
April 2019	409 (Now 413)	Acceptance by Certification can be used for parking lots
April 2019	409 (Now 413)	Change to Weather & Seasonal Limitations

Major Asphalt Related Changes in 408 Since April 2017 (Continued)

Date	Section	Description
October 2019	409 (Now 413)	Minimum compacted depth changed from 1 ½” to 2” for 12.5-mm mix (to obtain cores for measuring and accepting density for standard specification)
October 2019	409 (Now 413)	Change of material for painting existing vertical surfaces
October 2020	405	Removing reference to “Correction Action” related to Longitudinal Joint Density
April 2021	419	Allow use of HOLA with SMA Mixtures
October 2021	413	Clarification on Form TR-447 for entering Gmm for the Joint core.
October 2021	341 and 342	Use of Foamed Asphalt in addition to Emulsion in Cold Mixes
October 2021	413	Fixing subplot size once established

Major Asphalt Related Changes in Other PennDOT Publications Since April 2017

Effective Date	Publication #	CT # or SSP	Comments
12/21/2020	2 (POM)	H-20-065	Report delivered material using Electronic Ticketing System
4/1/2021	2 (POM)	C-20-002	Check temperature from truck bed holes
October 2019	13M		Safety Edge
October 2020	72M: RC-25M		Safety Edge Drawings
Not Established yet		H-20-053	Virtual Asphalt Acceptance Testing (VAAT)
2/12/2021	?	c04132	LLAP Hamburg Tracking and Cracking Tolerances
Next Updated Version	2 (POM)	C-21-003	% Pavement for Defective Asphalt Pavement

Pub 408 Table of Contents

Section	Title	
100	General Provisions	←
200	Earthwork	
300	Base Courses	←
400	Flexible Pavements	←
500	Rigid Pavements	
600	Incidental Construction	
700	Material	←
800	Roadside Development	
900	Traffic Accommodation & Control	
1000	Structures	
1100	Manufactured Material	
1200	Intelligent Transportation System (ITS) Devices	

Pub 408 Asphalt Related Specifications

106	Control of Material
313	Superpave Asphalt Mixture Design, Standard Construction, Base Course
316	Flexible Base Replacement
344	Full Depth Reclamation
341	Cold Recycled Asphalt Base Course (In-Pace)
342	Cold Recycled Asphalt Base Course (Central Plant)
360	Asphalt Treated Permeable Base Course
404	Evaluation of Asphalt Pavement Ride Quality and Payment of Incentive
405	Evaluation of Asphalt Pavement Longitudinal Joint Density And Payment of Incentive/Disincentive

Pub 408 Asphalt Related Specifications

410	Superpave Mixture Design, Standard & RPS Construction of Plant-Mixed Fine-Graded Courses
412	Superpave Mixture Design, Construction of Plant-Mixed 6.3 mm Thin Asphalt Overlay Courses
413	Superpave Mixture Design, Standard & RPS Construction of Plant-Mixed Courses with PWL and LTS Testing
419	Stone Matrix Asphalt Mixture Design, RPS Construction of Plant-Mixed Wearing Courses
420	Pervious Asphalt Pavement System
460	Asphalt Tack Coat
483	Polymer-Modified Emulsified Asphalt Paving System (Microsurfacing)
489	Ultra-Thin Bonded Wearing Course
496	Asphalt Concrete Pavement, 60-Month Warranty

Asphalt Standard Special Provisions

a10650	Minimum Effective Asphalt for 9.5 mm or 12.5 mm Superpave Mixtures
c0411	Item 4411-0010 Superpave Asphalt Mixture Design, WMA Binder Course (Leveling), 19-mm mix, <0.3 M ESALs, High RAP, effective 5/1/2018
b04003 and b04004	Superpave Asphalt Mixture Design, Standard and RPS Construction of Asphalt Pavements with Department Local Acceptance, and Payment by Percent Within Tolerance (PWT-HOLA)

Other Related Pub 408 Specifications

210	Subgrade
350	Subbase
450	Manual Asphalt Patching
461	Asphalt Prime Coat
469	Asphalt Joint & Crack Sealing
491	Milling of Asphalt Paving Surface
492	Profile Milling of Asphalt Paving Surfaces

Remember

- **408 specs are superseded by Supplemental Specifications which are superseded by special provisions.**
- **Standard Drawings (RC standards) are superseded by Construction Plans and Cross Sections.**

Overlay Transitions and Paving Notches

RC 28M (From PennDOT Pub 72M)

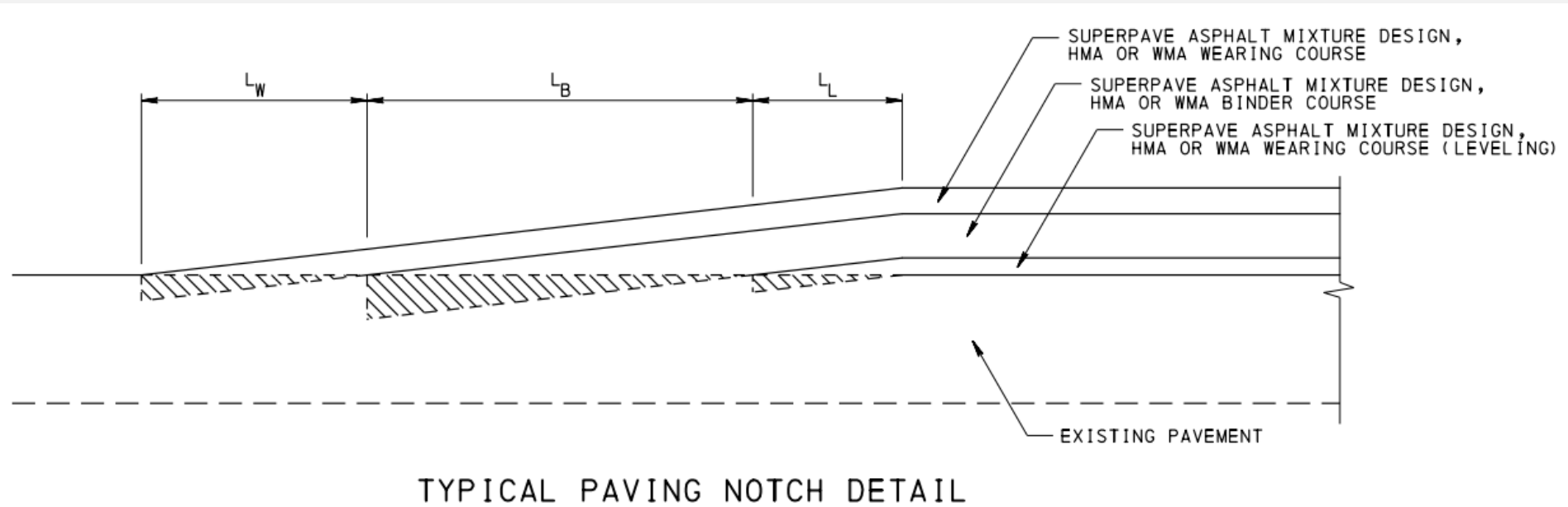

TYPICAL PAVING NOTCH DETAIL

LEGEND



DENOTES AN AREA OF THE EXISTING PAVEMENT TO BE MILLED TO PROVIDE PROPER TRANSITION FOR THE NEW PAVEMENT COURSE. THE DEPTH SHOULD EQUAL THE NOMINAL DEPTH OF THE NEW PAVEMENT COURSE AND GRADUALLY TAPER TO NOTHING OVER A LENGTH (L_w , L_b , OR L_l) SHOWN IN TABLE A. THE VARIABLE DEPTH MILLING IS INCIDENTAL TO THE PAVING ITEM.

L_w = THE MINIMUM LENGTH OF EXISTING PAVEMENT TO BE MILLED FOR THE WEARING COURSE.

L_b = THE MINIMUM LENGTH OF EXISTING PAVEMENT TO BE MILLED FOR THE BINDER COURSE.

L_l = THE MINIMUM LENGTH OF EXISTING PAVEMENT TO BE MILLED FOR THE LEVELING COURSE.

Overlay Transitions and Paving Notches

RC 28M (From PennDOT Pub 72M)

Milling Length for Transition

TABLE A

REGULATORY POSTED SPEED LIMIT (mph)	MINIMUM LENGTH OF MILLING		
	L_L	L_B	L_W
> 65	35'	80'	80'
≥ 55 TO < 65	35'	80'	60'
≥ 45 TO < 55	25'	35'	30'
< 45	15'	25'	20'

Remember...

- **Keep familiar with Pub 408 specifications and project special provisions**
- **Learn where to find particular specifications in Pub 408 and contract specific details**
- **Be sure that you are utilizing the appropriate change**

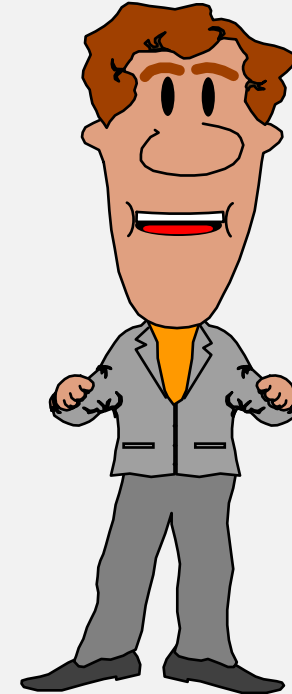

Merging Specification Sections

- Sections 309 (hot mix) and 311 (warm mix) of Spec 408/2016 were merged into **Section 313** in Spec 408/2020 Edition
- Sections 409 (hot mix) and 411 (warm mix) of Spec 408/2016 were merged into **Section 413** in Spec 408/2020 Edition
- Sections **313** and **413** are applicable to projects with PWL and LTS testing

Spec Sections Reviewed in Part 1

- **313** Superpave Asphalt Mix Design, Standard Construction, Base Course
- **316** Flexible Base Replacement
- **344** Full Depth Reclamation (FDR)
- **360** Asphalt Treated Permeable Base
- **412** Superpave Mixture Design, Construction of Plant Mixed 6.3 mm Thin Asphalt Overlay Courses
- **413** Superpave Mixture Design, Standard & RPS Construction of Plant-Mixed Asphalt Course
- **419** Stone Matrix Asphalt Mixture Design, RPS Construction of Plant-Mixed Asphalt Wearing Courses
- **420** Pervious Asphalt

Section 313
Superpave Asphalt Mix Design,
Standard Construction, Base
Course

Different Sections of Specifications

- **313.1 Description**
- **313.2 Materials**
- **313.3 Construction**
- **313.4 Measurement & Payment**

Note that construction related specifications are always in the “.3” portion of ANY section.

Section 313:

Superpave Asphalt Mix Design, Standard Construction, Base Course

- **Materials – follows 413.2**
- **Construction – follows 413.3 for Standard Spec, except:**
 - **(b) Weather Limitations: No Placement when**
 - prepared surface is wet or
 - air or surface temperature is **35°F or below**.
 - **(h) 1.b Spreading & Finishing:**
 - For 25.0 mm base and if compacted depth is **> 6"**:
 - place in two or more \approx equal lifts,
 - no lift $< 3"$ or $> 6"$.
 - For 37.5 mm base and if compacted depth is **> 8"**:
 - place in two or more \approx equal lifts
 - no lift $< 4"$ or $> 8"$.

Section 313:

Superpave Asphalt Mix Design, Standard Construction, Base Course

- **Construction – follows 413.3 for Standard Spec, except:**
 - **(l) Surface Tolerance:**
 - Pavement defective if irregularities are more than **1/4 inch**
 - **(m) Tests for Depth:**
 - One random core using PTM No. 1 on top lift in each 3000 sq. yds., with additional cores if deficiency suspected
 - Measure depth according to PTM No. 737.
 - Pavement defective if depth deficient by 1/2 inch or more

Section 316

Flexible Base Replacement

- **Ref: RC 28M, RC 30M (Pub 72M) for Drawings**
- **SAW or MILL perimeter of area to be replaced**
- **Vertical Edges clean and coated with PG 64-22**
- **Material placed to minimize segregation**

Section 344
Full Depth Reclamation (FDR)
A Review

Section 344

Full Depth Reclamation (FDR)

- In-place pulverizing and mixing of existing roadway materials
- Stabilizing additives and imported aggregate or RAP to specified depths
- Forms a base layer upon which an asphalt overlay or surface treatment is applied.
- Reclaimed material and RAP must have 95% passing 2-inch sieve
- Emulsified Asphalt: CMS-2, SS-1h, CSS-1h, CSS-1hPM
- Stabilizing Additives: Portland Cement, Hydrated Lime, Fly Ash, Pozzolans, Calcium Chloride, Magnesium Chloride
- All Projects must have an approved mix design.

Section 344 FDR Construction

- Reclaimer must be able to pulverize to a depth of 16 inches at 8 feet wide in one pass and control oversized material.
- Computerized control of injection of water and/or stabilizing agents.
- Motor Grader or approved method for shaping
- 20-ton pneumatic tire roller for 8" depth or less, and for final compaction of depths > 8"
- Vibratory pad foot roller for depths > 8"
- 12-14 ton static steel drum roller for finish rolling
- Allowed to cure until 7-day design strength is met



Section 344 FDR

Compaction and Acceptance

- One test for each 3,000 sq. yds.
- Density must be 95% of lab results using PTM 402
- Not to exceed 3/4” of irregularity for line, grade, or cross slope
- Surface tolerance: Not $> 1/2$ ” under 10-foot straightedge.
- Acceptance by surface tolerance and project density specs.

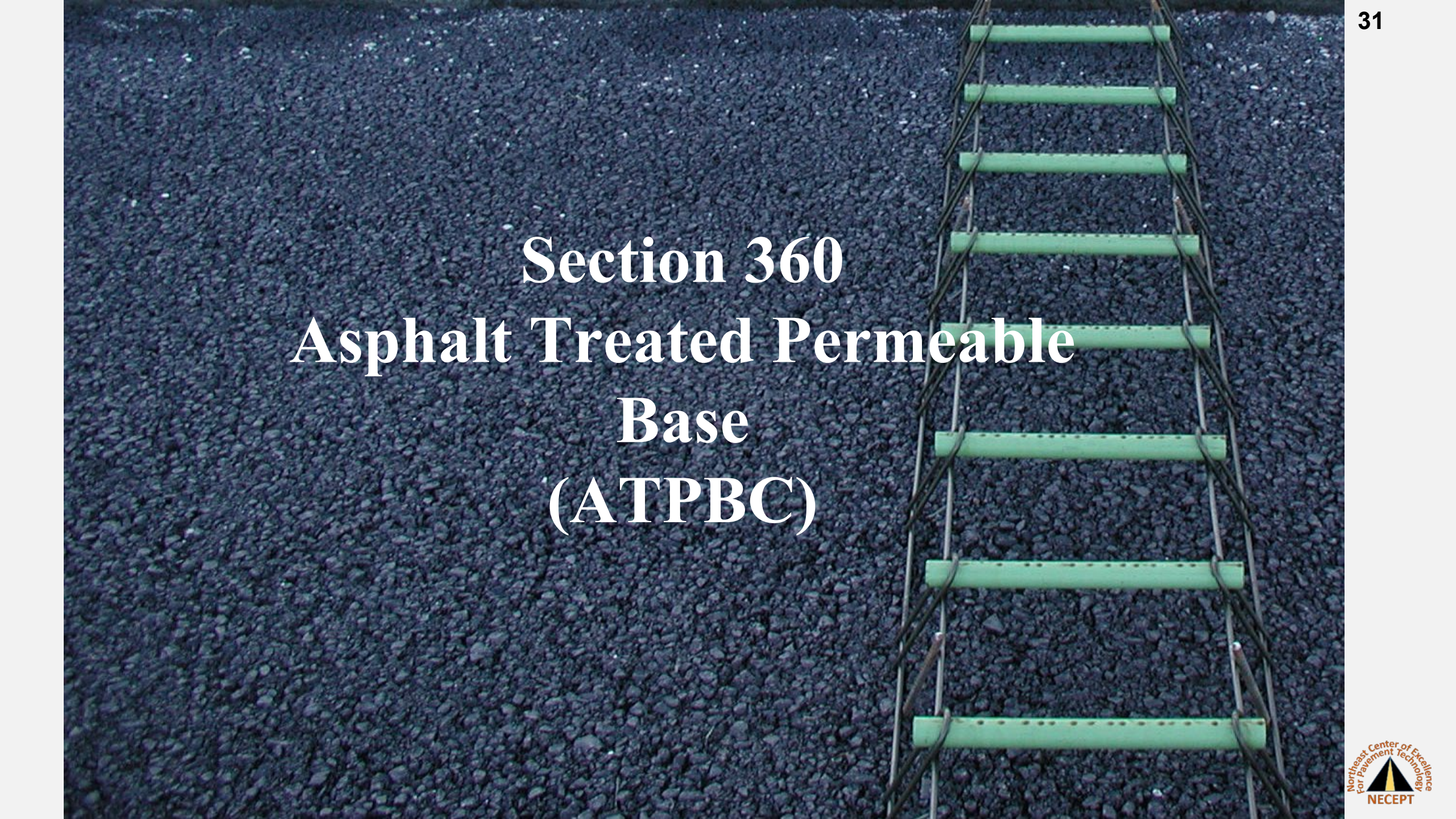

Section 360
Asphalt Treated Permeable
Base
(ATPBC)

Section 360

Asphalt Treated Permeable Base Course



Section 360

Asphalt Treated Permeable Base Course

- **Asphalt Material: Asphalt Cement, Class PG 64S-22**
- **Construction: follows 413.3 except:**
 - **(b) Weather Limitations: No Placement when**
 - Prepared surfaces unstable, frozen, or
 - Air or surface temperature is below 35°F
 - **(c)4. Preparation of Mixture:**
 - Produce ATPBC below 320°F
 - Do not stockpile
 - Place within 8 hours

Section 360

Asphalt Treated Permeable Base Course

- **Construction: follows 413.3 except:**
 - **(h) Spreading & Finishing:**
 - Maximum 4” compacted lifts,
 - mixture to cool to 100°F before placing subsequent layers
 - **(i) Compaction:**
 - Seat ATPBC with 8 to 10-ton steel wheeled rollers (static mode only).
 - Compact by 4 roller passes. Do not over compact.
 - **(j) Mat Density Acceptance:**
 - No Density Requirements

Section 360

Asphalt Treated Permeable Base Course

- **360.3 Construction: follows 413.3, except:**
 - **(l) Surface Tolerance:**
 - Testing with 10-foot straightedge in stages of 5 linear feet.
 - Pavement irregularities more than 1/2" need correction
 - DO NOT mill or grind the ATPBC
 - **(m) Tests for Depth:**
 - Dig or drill one 6" diameter test hole in each 3000 sq. yds, with additional cores if deficiency suspected
 - Measure depth , remove & replace if depth deficient by 1/2 inch or more
 - **(n) Protection of Courses:**
 - Traffic not permitted on ATPBC except to place next layer



Section 412
Superpave Mixture Design,
Construction of Plant Mixed
6.3-mm Thin Asphalt Overlay
Courses

Section 412

Superpave Mixture Design, Construction of Plant Mixed 6.3-mm Thin Asphalt Overlay Courses

- **Used in Thin Lifts (3/4" min, 1 1/4" max.)**
- **Useful Tool for Pavement Preservation**
- **An alternative to microsurfacing and seal coats.**
- **Mixture Details**
 - PG 64E-22 binder required
 - Coarse aggregate: Type A
 - Sand fine aggregate must be from the same source as coarse aggregate with SRL rating in Bulletin 14
 - No RAP or RAS in mix (virgin)

Section 412

6.3 mm Thin Overlay Courses

Construction details:

- $>50^{\circ}\text{F}$ air and surface temperature
- MTV required, unless waived by Rep.
- Box samples from roadway, hopper, or screed
- Density acceptance by optimum rolling pattern or non-movement



One-inch thick placed 6.3 mm, SR 220

Section 412

6.3 mm Thin Overlay Courses

Critical points for success:

- Clean existing surface.
- Proper, uniform tack application
- Selection of compaction rollers
- Begin Rolling immediately.
- Time available for compaction is limited.
- Do not use pneumatic-tire rollers.

Section 413
**Superpave Mixture Design,
Standard & RPS Construction
of Plant-Mixed Asphalt Course**

Section 413

Superpave Mixture Design, Standard & RPS Construction of Plant-Courses with Percent Within Limits and LTS Testing (PWL-LTS)

- **Standard and RPS construction of plant mixed asphalt** on a prepared surface using a volumetric mixture design developed with the Superpave Gyratory Compactor
- includes additives or modifiers, or plant process modifications or both.
- **Acceptance is based on testing of field samples by the LTS and statistical evaluation of sample test results by Percent Within Limits (PWL) procedures.**

Section 413

SP Mixture Design, Stand. & RPS Construction

- **Materials**
 - Sections 106 & 700, and Bulletins 14 & 15, and aggregate SRL
 - Addresses use of RAP, RAM, and RAS
 - Discusses Job-Mix Formula tolerance requirements for completed mix
- **Mixture Acceptance**
 - RPS Construction accepted by lots
 - For Standard Construction, use **Table C**:

Table C Mixture Acceptance

Acceptance Level	Acceptance Method
Certification Acceptance	Producer Certification of Mixture (Section 413.2(i)2)
Lot Acceptance	Mixture Acceptance Sample Testing (Section 413.3(h)2)

Section 413

SP Mixture Design, Stand. & RPS Construction

- **Acceptance by Certification is appropriate for**
 - Scratch or Leveling <2”, driveway adjustments.
 - Mixtures used by Dept. maintenance forces.
 - Mixtures used by municipal governments.
 - Small quantities < **500** tons in a continuous operation.
 - Mixtures used for parking lots
 - All **4.75** mm NMAAS asphalt mixtures
 - Other mixtures, conditions, or applications as approved

All others by Lot Acceptance!

Section 413

SP Mixture Design, Stand. & RPS Construction

- **No loose box** samples for JMF quantity < **500 ton**
- Coring allowed for density acceptance on materials accepted by Certification
- **submit the QC plan for the project using (Form CS-413)**

Should be discussed at pre-placement meeting

Section 413

SP Mixture Design, Stand. & RPS Construction

- **Weather Limitations**
 - ❑ **Paving allowed from April 1 to October 15 for the following wearing courses:**
 - **PG 64E-22 (PG 76-22)**
 - **>10M ESALs**
 - **4.75 mm mix**
 - **Other mixes compacted less than 1.5 inches.**

 - ❑ **Paving allowed from April 1 to October 31 for all other courses**

Section 413

SP Mixture Design, Stand. & RPS Construction

- **Weather Limitations**
 - Do not place asphalt mix when
 - **surfaces are wet**
 - **the temperature of air or surface $\leq 40^{\circ}\text{F}$**
- **Asphalt preplacement meeting scheduled at least 2 weeks before placement of mixture to review**
 - Specifications
 - QC plan
 - Paving sequence
 - Mixture & density acceptance
 - Care and custody of asphalt samples

Section 413, Table A

Temperature of Mixture (°F)				
Class of Material	Type of Material	Chemical, Organic, Foaming Additives, Minimum	Mechanical Foaming Equip/Process Minimum*	Maximum*
PG 58S-28	Asphalt Binder	215	230	310
PG 64S-22	Asphalt Binder	220	240	320
PG 64E-22	Asphalt Binder	240	260	330
All other binders	Asphalt Binder	The higher of 215 or the minimum temp. specified in Bulletin 25 minus 45F	The higher of 230 or the minimum temp. specified in Bulletin 25 minus 30F	As specified in Bulletin 25

* Outline in the Producer QC Plan and follow more restrictive temperature requirements provided by the WMA technology manufacturer or Technical Representative(s) for production and placement of the mixture. Determine the SGC compaction temperature for the production QC which yields the same target air voids as the designed JMF. Include the SGC compaction temperature in the Producer QC Plan. Compact the completed mixture in the SGC for QC volumetric analysis at the SGC compaction temperature according to the guidelines provided by the Technical Representative.

Extended-Season Paving

- **Written request at 14 calendar days prior to extended season paving**
 - Paving allowed from April 1 to November 15 for the following wearing courses:
 - **PG 64E-22 (PG 76-22)**
 - **>10M ESALs**
 - **4.75 mm mix**
 - **Other mixes compacted less than 1.5 inches.**
 - Paving allowed from March 1 to December 15 for all other courses:
- **Must use MTV for lengths > 1500 ft.**

Extended Season Paving

- Project Representative MUST release Material
- Extended season pre-placement meeting at least 5 days prior to review details of Extended Season Paving Plan (CS-413 ES)
- MUST follow Plan or STOP PAVING
- Density acceptance for RPS and standard paving on stable/uniform bases at Table G depths will be by pavement cores.
- CS-413 ES to be completed and provided to Dept. within 24 hours of completion of paving.
- Extended Season Fall paving will be subject to Spring Evaluation by May 1 as per Pub 336.

Section 413

SP Mixture Design, Stand. & RPS Construction

- **Construction**
 - **(d) Hauling Equipment**
 - Tightly sealed vehicles
 - Provide covers to protect entire load
 - **Provide insulation/heated or double-walled truck bodies when air temp is below 50°F from October 1 to April 30.**
 - **(e) 1 Asphalt Pavers**
 - Self-contained power-propelled units & other requirements
 - **(e) 2 Asphalt Wideners**
 - Self-contained power-propelled units & other requirements

Section 413

SP Mixture Design, Stand. & RPS Construction

- **Construction**

- **(f) Rollers**

- Steel-wheel, pneumatic tire, vibratory or oscillating rollers

- **(g) Preparation of Existing Surface**

- Clean & Correct irregularities in binder course
- Paint existing vertical surfaces with asphalt Class TACK, NTT/ CNTT in two or more applications or hot asphalt of class & type designated for course.
- Apply a tack coat, Section 460
- Place scratch and leveling courses as indicated

NOTE:

Paving Notches: Mill existing pavement surface at tie-in with wearing course (use Std Drawing RC -28M & Milling Section 491)

Scratch & Leveling Courses

- Use **scratch course** to fill wheel ruts & other local small depressions even with surrounding pavement'
- Use **leveling course** to provide a relatively uniform working platform for placing binder or wearing courses

Section 413

SP Mixture Design, Stand. & RPS Construction

- **Construction**

- **(h) Spreading and Finishing**

- Deliver and place at laying temperatures specified in Table A (Section 413.2(e)1.d.)

– PG 58S-28 215°F to 310°F

– PG 64S-22 220°F to 320°F

– PG 64E-22 240°F to 330°F

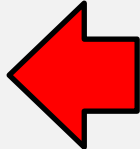
 **Asphalt
Temp.**

- Courses >6” in compacted depth, place in 2 or more equal layers, none <3” or >6” compacted depth
- Do not use rakes.

Section 413

SP Mixture Design, Stand. & RPS Construction

- **Construction**
 - **MTV required for RPS pavement**
 - **(h)1.c Field Technician**
 - **Provide Certified Asphalt Field Technician**
 - **Must be onsite**
 - **Must carry valid certification card**

Section 413

SP Mixture Design, Stand. & RPS Construction

- **Construction**
 - **(h)2 Mixture Lot Acceptance (Standard & RPS Construction)**
 - **(h)2.a Lots and sublots**
 - Lots established & specific for each JMF
 - Normal lot size = 2,500 Tons
 - Normal subplot size = 500 Tons (5 per lot)
 - 1 box sample + 1 core sample obtained from each subplot (PTM No. 1)

Section 413

SP Mixture Design, Stand. & RPS Construction

- **Lots and Sublots**
 - If project size or operational conditions dictate. Lot (*final lot*) will be adjusted as in Table D
 - Stoppages of 5 days or more, last lot will be adjusted as in Table D.
 - New lot established when work resumes after 5-day stoppage.

413.3(h)2.a Lots and Sublots: Table D

Re-adjustment of Lot Size & Associated Number of Sublots

Remaining Quantity* Following Last Full Lot	Action
Less than 500 tons <u>without</u> a combination of one mixture acceptance sample and one core	Quantity combined with previous lot, (n=5)
Less than 500 tons <u>with</u> a combination of one mixture acceptance sample and one core	One new subplot defined & quantity combined with previous lot, (n=6)
500 tons to less than 1000 tons <u>without</u> a combination of two mixture acceptance samples and two cores	One new subplot defined & quantity combined with previous lot, (n=6)
500 tons to less than 1000 tons <u>with</u> a combination of two mixture acceptance samples and two cores	Two new sublots defined & quantity combined with previous lot, (n=7)
1000 tons to less than 1500 tons <u>without</u> a combination of three mixture acceptance samples and three cores	Two new sublots defined & quantity combined with previous lot, (n=7)
1000 tons to less than 1500 tons <u>with</u> a combination of three mixture acceptance samples and three cores	New lot defined, (n=3)

413.3(h)2.a: Table D *continued*

Re-adjustment of Lot Size & Associated Number of Sublots

Remaining Quantity* Following Last Full Lot	Action
1500 tons to less than 2000 tons <u>without</u> a combination of four mixture acceptance samples and four cores	New lot defined, (n=3)
1500 tons to less than 2000 tons <u>with</u> a combination of four mixture acceptance samples and four cores	New lot defined, (n=4)
2000 tons to less than 2500 tons <u>without</u> a combination of five mixture acceptance samples and five cores	New lot defined, (n=4)
2000 tons to less than 2500 tons <u>with</u> a combination of five mixture acceptance samples and five cores	New lot defined, (n=5)

- **(h)2.a.1**
 - Partially Completed Lot (n=2 or less): When partially completed lot (2 sublots or less) cannot be combined with most recent completed lot, samples will be independently evaluated

Section 413

SP Mixture Design, Stand. & RPS Construction

- **JMF's less than 2500 tons**
 - JMF's > 500 tons and < 2500 tons, tonnage considered a lot and divided into 5 equal sublots
 - JMF's ≤ 500 tons, tonnage may be considered a lot and divided into 3 equal sublots, if density acceptance by pavement cores (an option) mixture acceptance is only by certification

****For total JMF less than 2500 tons,
Table D does not apply, do not use!***

Lot – Sublot Definitions

- ***Normal lot* size is 2500 tons with 5 sublots of 500 ton each.**
- ***A complete lot* will have at least 3, but no more than 7 sublots**
- **Lots with less than 3 sublots are “incomplete”**
- ***A complete sublot* MUST have a core and a loose (mixture or box) sample**

Section 413

SP Mixture Design, Stand. & RPS Construction

- **Evaluating Pattern Segregation**
 - Inspector will notify Contractor of observed pattern segregation
 - Contractor may continue at own risk
 - Project Representative will witness the PTM 751 (pavement surface macrotexture depth test)
 - Unacceptable segregation if average texture depth between the non-segregated area and segregated areas exceeds 0.024 inch.

Section 413

SP Mixture Design, Stand. & RPS Construction

- **Test Section for Segregation**
 - If segregation identified, stop paving!
 - Department will evaluate segregation to determine corrective work
 - Test section then placed, <200 tons
 - Resume normal paving after successful test section

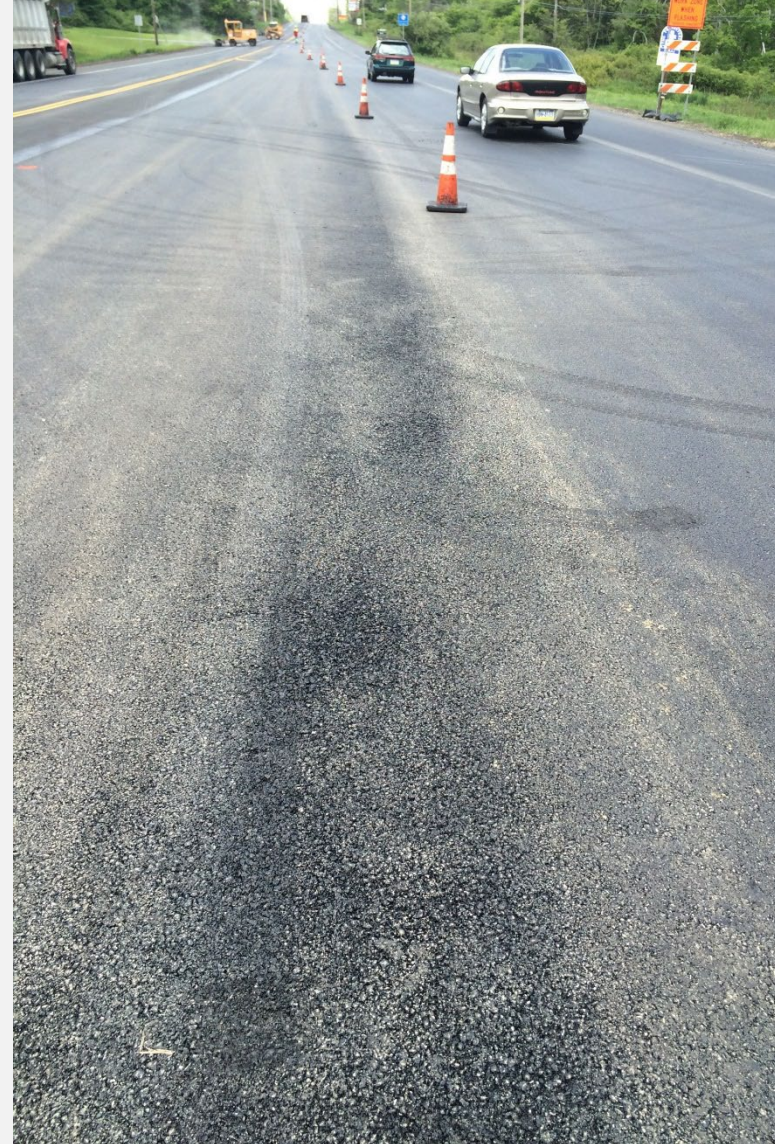

Section 413

SP Mixture Design, Stand. & RPS Construction

- **Defective Pavement because of Segregation**
 - Cores taken – 3 from segregated area & 3 from non-segregated area , tested for density, asphalt content and gradation
 - If tests determine pavement is defective, remove & replace full width of affected lane plus minimum of 5 feet beyond each end of unaccepted area.

Section 413

SP Mixture Design, Stand. & RPS Construction

- **Flushing**
 - Provide a mix that will not flush
 - Flushing is continuous or repeated areas of excessive asphalt on the pavement surface



Section 413

SP Mixture Design, Stand. & RPS Construction

- **Evaluating Flushing**
 - When flushing is observed, Project Representative will notify Contractor
 - Contractor may continue at its own risk while adjusting to eliminate further flushing
 - Average pavement surface macrotexture depth is determined by PTM 751 in suspected flushing area
 - If Average depth of macrotexture ≤ 0.006 inches, then. pavement considered flushed & defective

Section 413

SP Mixture Design, Stand. & RPS Construction

- **Test Section for Flushing**
 - If flushing identified, stop paving!
 - Department will evaluate flushing to determine corrective work
 - Remove & replace defective wearing course for full lane width + minimum 5 feet beyond each end of defective area
 - After Project Representative allows paving to resume, place test section not to exceed 200 tons.
 - Normal paving can be resumed after construction of an entire test section without flushing.

Section 413

SP Mixture Design, Stand. & RPS Construction

- **Compaction**

- Compact to achieve required density & eliminate all roller marks
- Adjust speed, amplitude, frequency, etc., to eliminate displacement, shoving, cracking, or aggregate breakage.
- Use pneumatic-tire for compacting scratch courses.
- For roller inaccessible areas, use mechanical vibrating hand tampers

Section 413

SP Mixture Design, Stand. & RPS Construction

- **Mat Density Acceptance**
 - Standard Construction (non-RPS): Density acceptance according to one of the levels in Table F
 - RPS: Density acceptance by Pavement Cores (lot acceptance)
 - Department determines density-acceptance level (QC Paving Plan)

Section 413

SP Mixture Design, Stand. & RPS Construction

- **Mat Density Acceptance**
 - Standard Construction (non-RPS)

Table F: Density Acceptance

<i>Density Acceptance Level</i>	<i>Acceptance Criteria</i>
Non-movement	Table H
Optimum Rolling Pattern	Table H
Pavement Cores*	Table I
*Only when mixture is accepted by lots	

**Cores may be used for density acceptance
for quantities < 500 ton**

Section 413

SP Mixture Design, Stand. & RPS Construction

- **Mat Density Acceptance**
 - **Non-Movement** (Density accepted when mix does not move under compaction equipment). Use for
 - **Scratch or leveling $< 1''$ or ≤ 110 lbs./yd².**
 - **Area of paving/patching $< 4'$ in width.**
 - **Following materials if determined non-critical for density:**
 - Materials placed in < 500 tons continuous.
 - Mixtures placed on unstable or non-uniform bases.
 - Mixtures used for patching, widening, shoulders*, driveway adjustments, or other miscellaneous applications.

**shoulders which are considered critical will be accepted by pavement cores*

Section 413

SP Mixture Design, Stand. & RPS Construction

- **Mat Density Acceptance**
 - **Optimum Rolling Pattern**
 - Materials placed in small quantities < 500 tons.
 - Mixtures placed on unstable or non-uniform bases.
 - Leveling or other courses $\geq 1''$ or ≥ 110 lbs./yd².
 - Mixtures used for patching, widening, shoulders*, driveway adjustments, or other miscellaneous applications.
 - Mixtures placed at < minimum compacted depths in Table G

**shoulders which are considered critical will be accepted by pavement cores*

Section 413

SP Mixture Design, Stand. & RPS Construction

- **Optimum Rolling Pattern**
 - Density tested by nuclear gauge (PTM 402) or electrical impedance gauge (PTM 403)
 - Inspector & contractor's certified field technician present
 - Nuclear gauge must have licensed operator
 - Use approved gauges or approved equal
 - Use procedure and forms in PTM 402/403



Section 413

SP Mixture Design, Stand. & RPS Construction

- **Mat Density Acceptance**
 - **Pavement Cores (Standard or RPS)**
 - Material placed at minimum compacted depths according to Table G.
 - Materials placed on stable and uniform bases

Section 413

SP Mixture Design, Stand. & RPS Construction

- **Mat Density Acceptance**
 - **Pavement Cores (Std or RPS)**

Table G: Mixture Minimum Compacted Depths

<i>Mixture</i>	<i>Minimum Depth</i>
9.5 mm Wearing Course	1 ½” (40 mm)
12.5 mm Wearing Course	2”(50 mm)
19 mm Wearing and Binder Courses	2 ½” (60 mm)
25 mm Binder Course	3” (80 mm)

Section 413

SP Mixture Design, Stand. & RPS Construction

- **Pavement Cores (Std or RPS)**
 - **Density Acceptance Samples**
 - Locations selected by PTM 1, PTM 729, & PTM 746
 - 6-inch cores no later than day following placement
 - If damaged, replacement obtained from within 12 inches of original
 - Hole backfilled with same JMF & sealed within 24 hours

Section 413

SP Mixture Design, Stand. & RPS Construction

- **Pavement Cores (Std or RPS)**
 - **Density Acceptance Samples**
 - Normal lot size = 2,500 Tons
 - Normal subplot size = 500 Tons (5 per lot)
 - 1 core obtained from each subplot
 - Identify by lot & subplot, location, placement date, mixture type, & as acceptance samples (Sample Class AS)
 - Submit samples for one lot in one container.
 - Cores tested by LTS

Section 413

SP Mixture Design, Stand. & RPS Construction

- **Pavement Cores (Std or RPS)**
 - **413.3(j)4.d Acceptance Sample Testing**
 - Density cores tested according to PTM 715 & PTM 716
 - Acceptance as specified in Section 413.4(a)4 or 413.4(b)
 - If cores not taken within 1 day after mix placement or if density for 2 consecutive lots or a total of 3 lots does not meet density requirement for 100% payment, stop paving operations.
 - Pavement resumes after evaluation of problem, approved proposed solution, & Department authorization

Section 413

SP Mixture Design, Stand. & RPS Construction

- **(k) Joints**
 - **(k)1. Longitudinal Joints**
 - **We Will Watch the Video in Part 2.**

Section 413

SP Mixture Design, Stand. & RPS Construction

- **Surface Tolerance**
 - Test with 12-foot straightedge
 - Defective if irregularities $>3/16''$
- **Tests for Depth**
 - Density acceptance by lots, measure depth of each subplot core (PTM 737)
 - Defective if depth deficiency $>1/4''$ or depth deficiency in 3 or more adjacent cores $>1/8''$ **as measured by PTM 737**

Section 413: Superpave Mixture Design, Standard & RPS Construction

- **Protection of courses**
 - No traffic for 24 hours or mat temp. is 140°F or less *and adequate stability and adhesion is obtained*
- **Defective work**
 - Remove, replace or repair defective work as directed

Time Available for Compaction (TAC)

Computer Program used to determine TAC



 **PaveCool** Asphalt Pavement Cooling Tool
© 2000-2006 Minnesota Department of Transportation

Free Download from Website:

<http://www.dot.state.mn.us/app/pavecool/index.html>

**RECOMMENDED MINIMUM MIXTURE LAYDOWN TEMPERATURE
BY COMPACTED THICKNESS FOR HOT MIX ASPHALT* CONTAINING PG 64-22**

Surface Temperature	3/4"	1"	1½"	2"	3" and greater
40 to 50 °F	-	310 °F	300 °F	285 °F	275 °F
50 to 60 °F	310 °F	300 °F	295 °F	280 °F	270 °F
60 to 70 °F	300 °F	290 °F	285 °F	275 °F	
70 to 80 °F	290 °F	285 °F	280 °F	270 °F	
80 to 90 °F	280 °F	275 °F	270 °F		
90 °F	275 °F	270 °F			
Rolling Time (min.)	6	8	12	15	15

Section 413: Superpave Mixture Design, Standard & RPS Construction

- **Measurement & Payment**

- **Mixture Acceptance by Certification & Density Acceptance by Non-Movement and Optimum Rolling Pattern**

TABLE H: Contract unit price adjustments - Mixture Acceptance by Certification

- **Mixture Acceptance by Lot and & Density Acceptance by Non-Movement, Optimum Rolling Pattern, or Pavement Cores**

TABLE I: Upper & Lower Spec Limits for Calculating Percent Within Tolerance

TABLE J: Dispute Resolution Retest Cost Table

Section 413.4: Measurement & Payment

TABLE H - Mixture Acceptance by Certification

For Asphalt Content

NMAS	Criteria	Value		PF, %
All sizes	Printed Tickets	<u>At least 90%</u> is ± 0.2 of JMF		100
		<u>Less than 90%</u> is ± 0.2 of JMF		85
19 mm and smaller	QC Sample Testing	Single, n=1	$n \geq 2$	-----
		$\pm 0.7\%$	$\pm 0.5\%$	100
		$\pm 0.8\%$ to 1.0%	$\pm 0.6\%$	85
		$> \pm 1.0\%$	$\geq \pm 0.7\%$	RR or 50%
25 mm and larger	QC Sample Testing	$\pm 0.8\%$	$\pm 0.6\%$	100
		$\pm 0.9\%$ to 1.2%	$\pm 0.7\%$	85
		$> \pm 1.2\%$	$\geq \pm 0.8\%$	RR or 50%

Section 413.4: Measurement & Payment

**TABLE H - Mixture Acceptance by Certification
For Gradation**

NMAS	Criteria	Value		PF, %
		n=1	n≥ 2	
All sizes	QC Sample Testing for % Passing #200 Sieve	±3.0%	±2.1%	100
		±3.1% to ±4.0%	±2.2% to ±2.7%	85
		> ±4.0%	≥ ±2.8%	RR or 50%
All sizes	QC Sample Testing for % Passing #8 Sieve	±6%	±4%	100
		±7% to ±8%	±5%	85
		> ±8%	≥ ±6%	RR or 50%

See footnotes of Table H for details

413.4 Measurement and Payment

- **(a)4.**
 - **Mixture Acceptance by Lot**
 - and**
 - **Density Acceptance by**
 - ✓ Non-Movement
 - ✓ Optimum-Rolling Pattern
 - ✓ Pavement Cores

**Adjust Payment according to PWL.
Use Upper and Lower Spec Limits in Table I.**

Section 413.4: Measurement & Payment

Mixture Acceptance by Lot

For Asphalt Content	Testing Criteria	
	Lower Spec Limit (L)	Upper Spec Limit (U)
Mixture NMAS	Asphalt Content from JMF, %	
9.5 mm, 12.5 mm	-0.4	+0.4
19 mm	-0.5	+0.5
25 mm and 37.5 mm	-0.6	+0.6

Section 413.4: Measurement & Payment

Mixture Acceptance by Lot

For Gradation

	Testing Criteria	
	Lower Spec Limit (L)	Upper Spec Limit (U)
Mixture NMAS	Passing No. 200 Sieve from JMF, %	
All Sizes	-1.5	+1.5
	Passing PCS from JMF, %	
9.5 mm (PCS=2.36 mm)	-5	+5
12.5 mm (PCS=2.36 mm)	-5	+5
19 mm (PCS=4.75 mm)	-8	+8
25 mm (PCS=4.75mm)	-9	+9
37.5 mm (PCS =4.75 mm)	-9	+9

PCS = Primary Control Sieve

Section 413.4: Measurement & Payment

Mixture Acceptance by Lot

For Mat Density

Mixture NMAS	Testing Criteria	
	Lower Spec Limit (L)	Upper Spec Limit (U)
	Mat Density *	
All 9.5 mm, 12.5 mm Sizes	92.0	98.5
All 19 mm Courses, 25 mm Binder Courses	91.0	98.0
25 mm and 37.5 mm Base Courses	90.0	No Upper Limit
* Where limits=percent theoretical maximum density)		

Section 413.4: Measurement & Payment

Mixture Acceptance by Lot

- 1. Lot results on asphalt content, gradation, and density are used with lower and upper spec limits to determine Percent Within Limits (PWL).**
- 2. PWL for each parameter is used to determine a single Pay Factor (PF) for that parameter.**
- 3. An overall pay factor (OLPF) is determined from combination of individual pay factors. See next slide.**

Section 413.4: Measurement & Payment

Mixture Acceptance by Lot

$$\begin{aligned} \text{OLPF} = & (0.50 \times \text{PF}_D) + \\ & (0.30 \times \text{PF}_{AC}) + \\ & (0.10 \times \text{PF}_{200}) + \\ & (0.10 \times \text{PF}_{PCS}) \end{aligned}$$

Where

OLPF = Overall Lot Pay Factor

PF_D = Pay Factor for In-Place Density

PF_{AC} = Pay Factor for Asphalt Content

PF_{200} = Pay Factor for Percent Passing the 75 mm (No. 200) Sieve

PF_{PCS} = Pay Factor for Percent Passing the Primary Control Sieve (PCS)

Section 413.4: Measurement & Payment Mixture Acceptance by Lot

$$\text{LOT PAYMENT} = C_p (\text{OLPF})/100$$

Where

**C_p = Contract unit price per lot
(unit price times lot quantity)**

and

OLPF = Overall Lot Pay Factor

Section 419
Stone Matrix Asphalt Mixture
Design, RPS Construction of Plant-
Mixed Asphalt Wearing Courses



Section 419 Stone Matrix Asphalt Mixture Design, RPS Construction of Plant-Mixed Asphalt Wearing Courses

- **RPS construction of plant-mixed Stone Matrix Asphalt (SMA) on a prepared surface**
- **Materials:** Refers to Sections 106 & 700; discusses aggregates, SRL, use of stabilizers, Job-Mix Formula and tolerance requirements for completed mix
- **Mixture Composition:**
 - Table A (Section 413.2(e)1.d.5)
 - Temperature of Mixture
PG 64E-22 240°F to 330°F
- **Mixture Acceptance:**
 - By lot acceptance
 - Not accepted by certification

Dense Graded vs. SMA (Gap Graded)

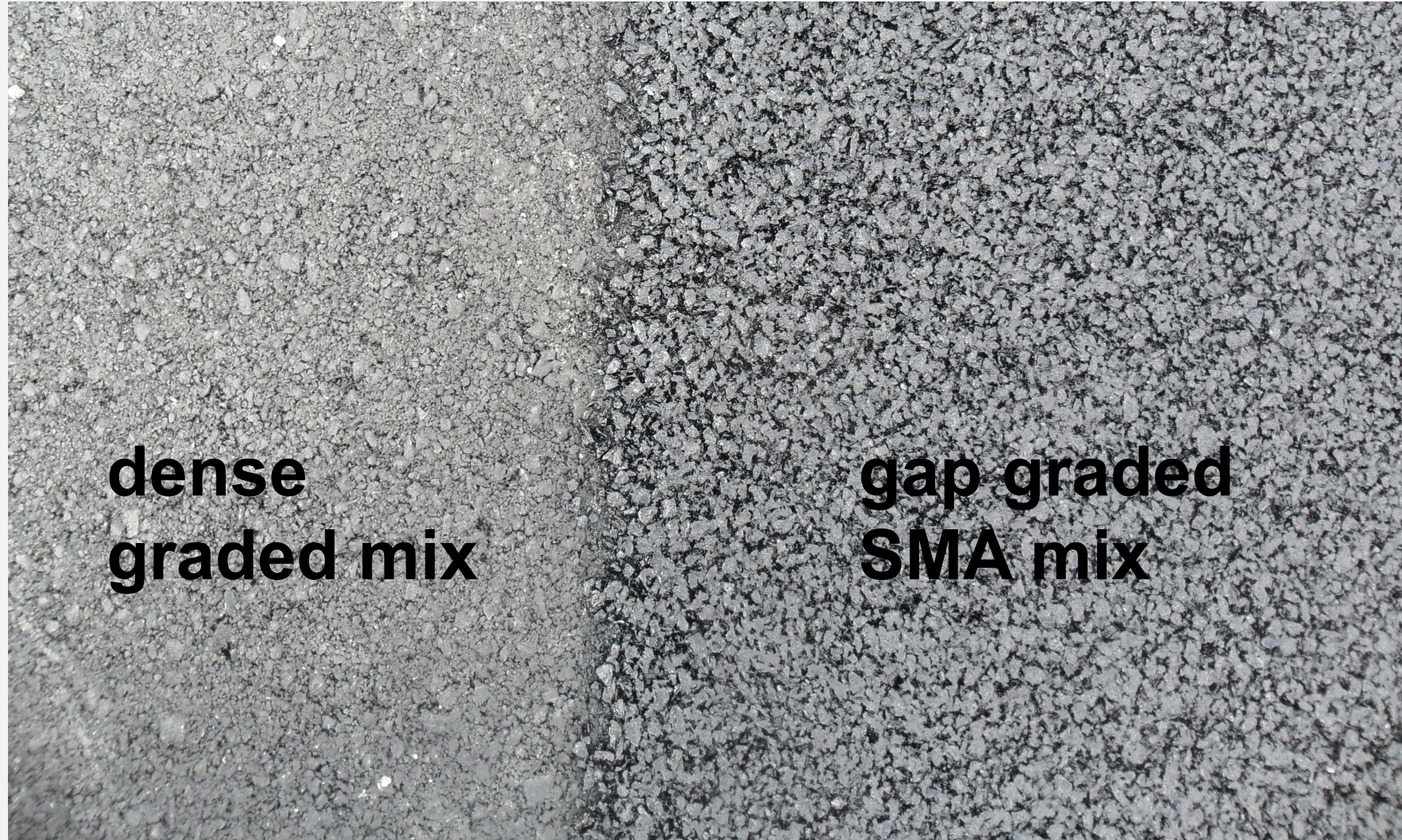

Section 419: Stone Matrix Asphalt, RPS Construction

- **Construction**

- **(a) Paving operation QC Plan:** Refers to 413.3(a), Contractor must submit a paving operation QC plan for the project **(Form CS-413)**
- **(b) Weather Limitations:** Paving prohibited:
 - when surfaces are wet
 - when the temperature of air or surface $\leq 50^{\circ}\text{F}$
 - Paving prohibited from Oct 1 OR Oct 16 to March 31 (depends on County)

Section 419: Stone Matrix Asphalt, RPS Construction

- **Construction**
 - **(d) Hauling Equipment:** Refers to 413.3(d)
 - **(e) Asphalt Pavers:** Refers to 413.3(e)
 - **(f) Rollers**
 - Minimum 3 steel-wheeled rollers, each with 10-ton weight
 - Do not operate in vibratory mode unless demonstrated and approved that no breaking of aggregate or flushing of asphalt binder results

Section 419: Stone Matrix Asphalt, RPS Construction

- **Construction**

- **(g) Demonstration**

- Before paving, perform trial demonstration outside projects limits by placing minimum of 100 tons.
 - Simulate actual hauling time for project
 - Obtain & test 3 loose mixture samples at plant for asphalt content, gradation, & draindown & 3 cores from demo pavement for density
 - If vibration is to be used, demo vibratory rolling

Section 419: Stone Matrix Asphalt, RPS Construction

- **Construction**
 - **(h) Preparation of Existing Surface: Refer to Section 413.3(g)**
 - **(i) Spreading & Finishing:**
 - 1.a Placing. Use MTV to apply final surface course (MTV to provide additional mixing)
 - 1.b Spreading & Finishing. Refer to Section 413.3(h)1.b, do not allow surface to flush
 - 1.c Field Technician. Refer to Section 413.3(h)1.c, Field Technician required

Section 419: Stone Matrix Asphalt, RPS Construction

- **Construction**

- **(i) Spreading & Finishing:**

- (i)2. Mixture & Density Lot Acceptance**

- Lot acceptance required for RPS construction
 - Lot is 2500 tons with 5 sublots of 500 tons each
 - One core obtained from each sublot for density acceptance
 - Two loose box samples obtained from each sublot: one for mixture acceptance and one for Gmm verification

Section 419

Stone Matrix Asphalt, RPS Construction

- **Construction**

NOTE: A completed subplot will contain one core sample and two loose mixture (box) samples

WHY?

This spec is to address the need for the Gmm verification sample

Section 419

Stone Matrix Asphalt, RPS Construction

- **G_{mm} Verification Samples**
may be taken from auger tunnel or UNCOMPACTED MAT and may require an additional random sampling procedure;

This must be discussed at the pre-placement meeting and may vary by project and District.

Section 419

Stone Matrix Asphalt, RPS Construction

- **Construction**

- **(i) Spreading & Finishing:**

- (i)2. Mixture & Density Lot Acceptance**

- Project quantities of > 500 to < 2500 tons, the quantity will be divided into 5 equal sublots

- Project quantities of 500 tons or less the quantity will be divided into 3 equal sublots

Section 419

Stone Matrix Asphalt, RPS Construction

- **Construction**

A completed LOT must have a minimum of 3 sublots

An incomplete (PARTIALLY COMPLETED) lot may have one or two sublots and are tested under different criteria

Section 419

Stone Matrix Asphalt, RPS Construction

- **Construction**
 - **(j) Compaction:** Follows Section 413
with rollers as specified in Section 419.3(f)
 - **(k) Mat Density Acceptance**
 - 93%-98% for 100% payment (Table F,
Section 419.4(a)3
 - **(l) Joints: Follows Section 413.3(k)**
(Vertical or Notched Wedge Joint allowed)

Section 419

Stone Matrix Asphalt, RPS Construction

- **Construction**
 - **(m) Surface Tolerance:** Section 413.3(1)
 - **(n) Tests for Depth:** Section 413.3(m)
 - **(o) Protection of Courses:** Section 413.3(n)
 - **(p) Defective Work:** Remove & replace as specified for Section 413 (Flushing, surface tolerance, depth, etc.)

Section 420

Pervious Asphalt

- Allows infiltration of surface water
- 9.5-mm or 19-mm mixes
- Ambient temperature $\geq 50^{\circ}\text{F}$
- NO tack between layers
- 4 passes with static steel drum roller
- No pneumatic tire roller allowed
- DO NOT over compact or crush aggregate
- Surface irregularities $> 3/8$ inch are unacceptable
- Do NOT grind or mill
- Cool to 100 degrees between layers

Summary (Part 1)

- **Discussed key elements of several Spec sections:**
- **313** Superpave Asphalt Mix Design, Standard Construction, Base Course
- **316** Flexible Base Replacement
- **344** Full Depth Reclamation (FDR)
- **360** Asphalt Treated Permeable Base
- **412** Superpave Mixture Design, Construction of Plant Mixed 6.3 mm Thin Asphalt Overlay Courses
- **413** Superpave Mixture Design, Standard & RPS Construction of Plant-Mixed Asphalt Course
- **419** Stone Matrix Asphalt Mixture Design, RPS Construction of Plant-Mixed Asphalt Wearing Courses
- **420** Pervious Asphalt

Asphalt Construction Program

Certified Asphalt Field Technician

An Update on PennDOT Specifications (Part 2)



Spec Sections Reviewed in Part 2

- **404** Evaluation of Asphalt Pavement Ride Quality and Payment of Incentive
- **405** Evaluation of Asphalt Pavement Longitudinal Joints Density and Payment of Incentive/Disincentive
- **413** Superpave Mixture Design, Standard & RPS Construction (The Part on Discussion of Joints)
- **460** Asphalt Tack Coat
- **483** Polymer-Modified Emulsified Asphalt Paving System (Micro Surfacing)
- **489** Ultra Thin Bonded Wearing Course

**And Brief Discussion of WMA Technologies
&
Safety Edge**

Section 404
Evaluation of Asphalt
Pavement Ride Quality and
Payment of Incentive

Section 404

Evaluation of Asphalt Pavement Ride Quality and Payment of Incentive

Evaluating asphalt pavement surface profile & determining ride quality incentive

- Measure surface profile (IRI) using PTM No. 428
- Determine payment based on the IRI
- Various exclusions:
 - ramps less than 1500 feet in length
 - tapers, shoulders, transition areas, bridge approaches, etc.

IRI = International Roughness Index

Section 404

Ride Quality and Payment of Incentive

Verification Process

- IRI values and payment data to be verified on random projects (FHWA req.)
- Data sent to PennDOT BOMO for verification
- PennDOT needs lot IRI summary AND raw, unfiltered data files (see PTM 428 for details)

Section 404

Ride Quality and Payment of Incentive

Lot Size

- Full lot = **528 feet** of a single lane of pavement (1/10th mile)
- Lots start at beginning of paving and continue to end of paving for each pavement lane and ramp that is 12 feet or wider
- Partial lot designated at end of paving or at an excluded area and evaluated as a percentage of a full lot

Section 404

Ride Quality and Payment of Incentive

Construction

- **Equipment & Operator**
 - The equipment meets requirements of **PTM No. 428**
 - Calibrate distance sensor
 - Check profile system calibration daily in presence of Inspector
 - **Provide A PennDOT certified operator**

Section 404

Ride Quality and Payment of Incentive



Section 404

Ride Quality and Payment of Incentive

Testing

(1) Lots

- Provide traffic control, clean pavement as necessary
- Determine surface profile of each lot according to **PTM No. 428**, in presence of Inspector

(2) Excluded Areas

- Measure with 12 -foot straightedge, parallel to centerline
- Advance in five-foot increments

Section 404

Ride Quality and Payment of Incentive

Acceptance

1. Lots. Corrective action needed if

- IRI exceeds max. value of Table A (Section 404.4)
- Irregularity **greater than 3/16"** when tested with a 12-foot straightedge

2. Excluded Areas. Not included for incentive payment

- To be corrected if irregularities **more than 3/16"**

Section 404

Ride Quality and Payment of Incentive

Corrective Action

- Perform before testing for pavement depth
- Use carbide grinding, diamond grinding, or remove & replace
- Produce surfaces that are neat, of uniform texture, with not more than **1/8-inch deviation** (such as ridge or valley) with existing pavement

Section 404

Ride Quality and Payment of Incentive

Defective Work:

- **Lot is defective if:**
 - IRI exceeds maximum acceptable IRI specified in **Table A** Schedule A or B
 - Any individual bump with irregularity of more than **3/16”**
 - Surface adjacent to another lot deviates more than **1/8”**
- **Remove & replace defective areas and retest lot**

Section 404

Ride Quality and Payment of Incentive

Measurement & Payment

- **Payment:**
 - Lots not defective will be paid according to IRI using **Table A** Schedule A or B
 - On defective lots, payment based on retest for IRI after corrective action.
 - Remove & replace defective areas and retest lot

Section 404

Ride Quality and Payment of Incentive

Table A

Schedule for Ride Quality Incentive

Schedule A

For Expressway Work Using Three Operations

IRI inches/mile/lot	Amount
≤ 35	\$600
≤ 50	\$300
≤ 60	\$150
≤ 70	\$0
> 70	Corrective Action Required

Section 404

Ride Quality and Payment of Incentive

Table A

Schedule for Ride Quality Incentive Schedule B

For Expressway Work Using Two Operations And
Non-Expressway Work Using Two or More Operations

IRI inches/mile/lot	Amount
≤ 45	\$600
≤ 55	\$300
≤ 70	\$150
≤ 90	\$0
> 90	Corrective Action Required

Section 404

Ride Quality and Payment of Incentive

At least two of these operations must be indicated in areas included in ride-quality lot measurement:

- Profile Milling (Section 492)
- Asphalt Base Course
- Asphalt Scratch Course
- Asphalt Leveling Course
- Asphalt Binder Course
- Asphalt Wearing Course

Section 405
Evaluation of Asphalt
Pavement Longitudinal Joints
Density and Payment of
Incentive/Disincentive

Section 405

Evaluation of Asphalt Pavement Longitudinal Joints Density and Payment of Incentive/Disincentive

- **Usage: For use on any project meeting ALL of the following criteria:**
 - RPS (regardless of network) or Standard pavements on the National Highway System (NHS)
 - Density acceptance by cores
 - Length of testable longitudinal joint **>12,500 feet**

Section 405

Longitudinal Joints Density and Payment of Incentive/Disincentive

- **Work**
 - Evaluating longitudinal joint samples on the surface wearing course for determining densities and the incentives/disincentive
- **Construction**
 - Lots for this spec **completely independent** from lots defined in other sections of the Specs for pavement acceptance
- **Lot Size**
 - **Full lot is 12,500 feet** of longitudinal joint
 - 5 sublots of 2,500 feet per full lot
 - One joint core drilled per subplot as paving progresses until full lot obtained
 - Single lot need not be contiguous & may include multiple joints within project

Section 405

Longitudinal Joints Density and Payment of Incentive/Disincentive

- **Quality Control Strip**
 - **On first day** paving of long. joint, obtain **5 randomly located core** samples on long. joint for QC density testing (this is in addition to incentive/disincentive payment subplot joint cores)
 - Cores to be tested and results supplied **within 24 hours**
- **Excluded Areas. Following joint areas excluded from lots:**
 - Joints where one or both sides pavement were accepted for density by other means
 - Joints where one side is formed by existing pavement not constructed under this project
 - Areas within **1 foot longitudinally** of an obstruction
 - Small areas (intersections, gores, transitions) not allowing for consistent joint construction

Section 405

Longitudinal Joints Density and Payment of Incentive/Disincentive

- **Sampling**

- One 6-inch core in each subplot located using **PTM 1 and PTM 729** no later than day following placement.
- For vertical joints center core over surface joint.
- For notch-wedge joints, center core 6 inches or one half of joint taper width away from joint line in direction of wedge.
- Identify by lot & subplot, location, placement date, mixture type, & as acceptance samples (Sample Class AS)
- Cores tested by LTS
- If damaged, replacement obtained from within **12 inches** of original
- Hole backfilled with same JMF & sealed within **24 hours**

Section 405

Longitudinal Joints Density and Payment of Incentive/Disincentive



Section 405

Longitudinal Joints Density and Payment of Incentive/Disincentive

- **Percent Within Limits (PWL)**
 - For each lot, PWL and average density determined.
 - Lower Spec Limit to find PWL is 91%
 - No Upper Spec Limit
- **Measurement and Payment**
 - Uses Percent within Tolerance (PWT) from Section 106.03(a)3 in Table A of Section 405.4 for payment by lot.
 - Partial lots with **fewer than 3 sublots** are combined with the previous lot.
 - Partial lots **with three or more sublots** will stand as a separate lot.

Section 405

Longitudinal Joints Density and Payment of Incentive/Disincentive

- Lower density limit for incentive payment is $\geq 90\%$ per lot
- Full incentive for $\geq 92\%$ per lot
- Maximum disincentive **\$10,000** per lot
- Lots with density $\geq 89\%$ but $< 90\%$ maximum disincentive of \$1,000 per subplot.

Section 413.3(k) Joint Construction

Section 413.3(k): Joint Construction

- **Longitudinal Joints**

- Offset joints ~ **6 inches**
- Joint in top layer at centerline of 2-lane roadways & within 12” of lane in multilane roadways
- Avoid joints directly beneath planned pavement markings
- Before placing abutting lanes, paint joint face with PG binder in mix or PG 64S-22.
- Placement of mix adjacent to compacted lane, overlap previously placed lane by **1 to 1 ½ inches**
- DO NOT bump back or lute overlapped material
- Compact joint with first forward pass of roller **6 to 12 inches** from the joint; then overlapping the joint **2 to 6 inches** on the backward and subsequent passes

Section 413.3(k): Joint Construction

- **Longitudinal Joints**

- All longitudinal joints need to be overbanded with PG 64S-22 binder.
- Overband must be **4±1 inches**.
- Thickness of band: **1/16" ± 1/32"**
- Temperature of sealant: between 265°F and 320 ° F
- Sealant placed when air temperature is ≥ 40 F

Overbanding the Joint

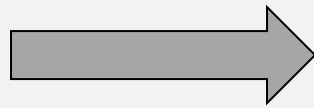

Section 413.3(k): Joint Construction

- **Longitudinal Joints**

- **Vertical Joints**

- For base, binder and wearing courses
- Place abutting lane same day, leaving less than **25 lineal feet** of exposed edge

- **Notched Wedge Joints**

- For wearing & binder course with nominal maximum aggregate size of 19.0 mm or smaller
- Use Standard Drawing RC-28
- If joint next to opposing traffic, place abutting lane within 1 day
- If next to traffic in same direction, place abutting lane within 2 days

PA's Notched Wedge Joint

Pub 72M, Standard RC-28

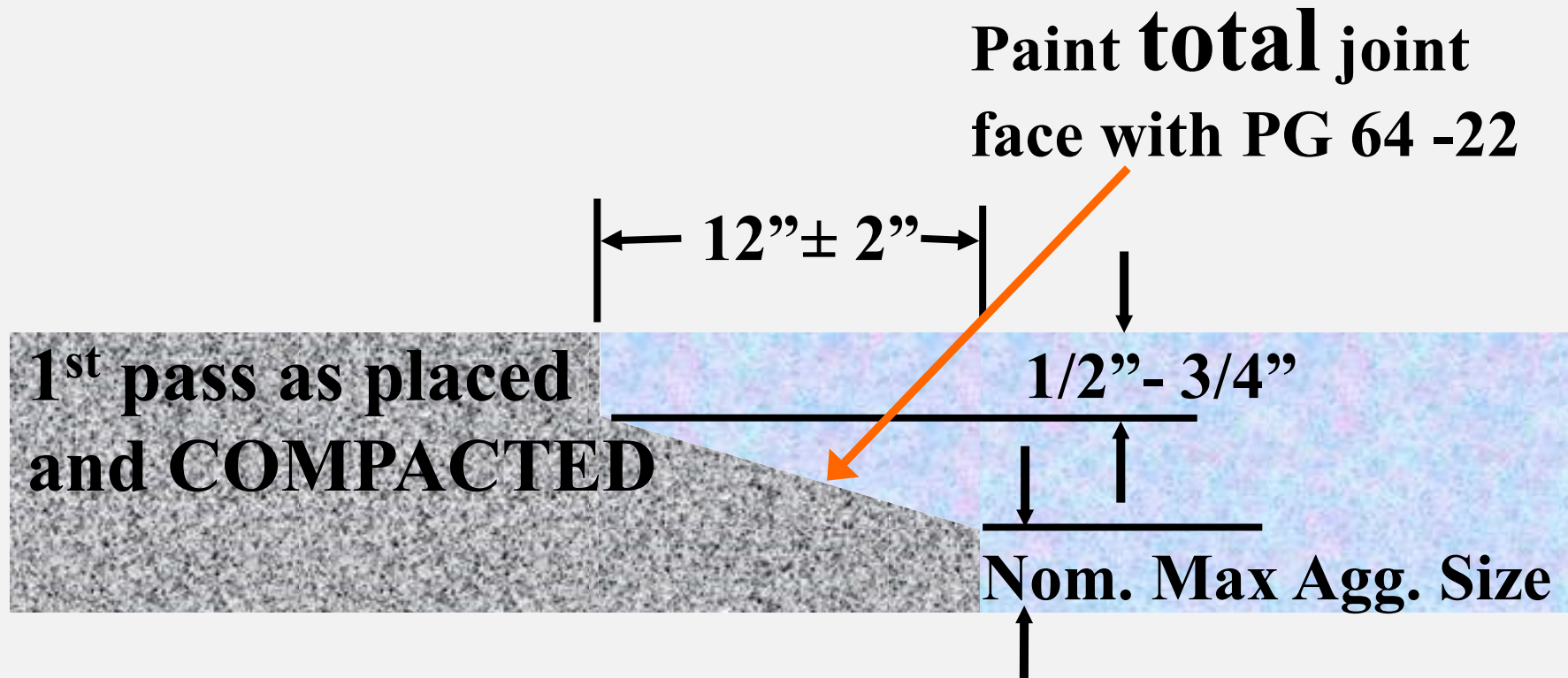

Longitudinal Joint Construction

Paint joint faces with PG 64 -22 binder

- Or PG in mix
- Thin even application
- Helps bonding, waterproofing and filling voids



What We Don't Want



2014/10/13

Trial Unit for Forming and Compacting NWJ



Why New Procedures?

Common sight on Pennsylvania Highways



Longitudinal Joint Construction

- 1) **Plan work to minimize longitudinal joints**
 - No joint always superior
 - Utilize paver extensions when practical & cost effective
 - Pave in echelon (two pavers) creating a hot joint for superior performance
 - Does this joint need TACK?



Longitudinal Joint Construction

2) Offset joints from layer below by 6”

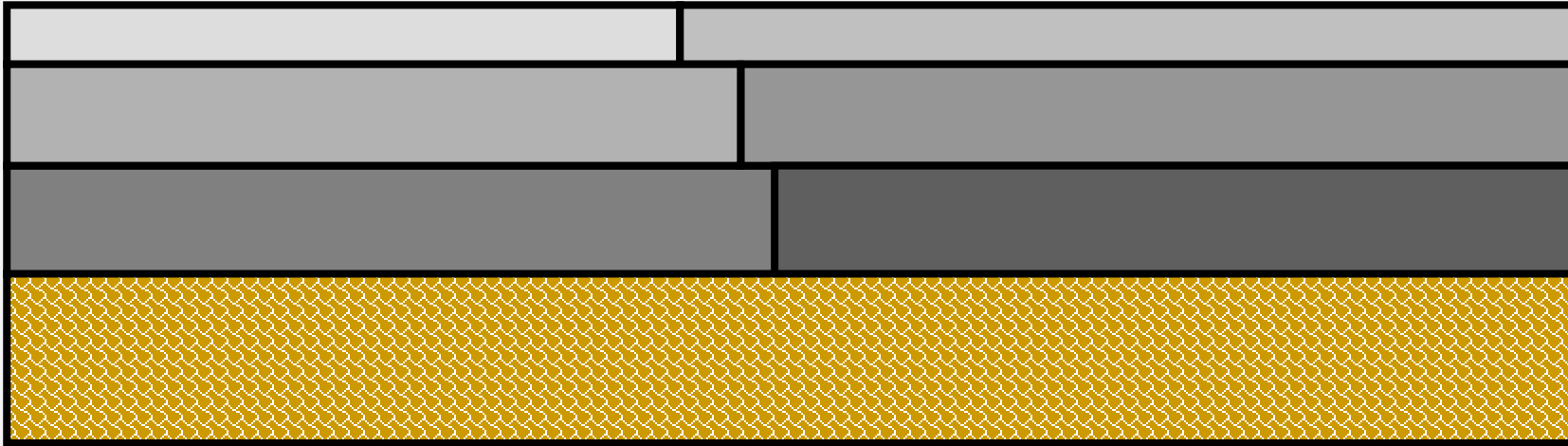

Where should the top surface joint be located?

**note narrow line
and similar texture
on both lanes**

Longitudinal Joint Construction

Do not “bump” material, NO Luting-----
just roll overlapped material into pavement



“DO NOT”

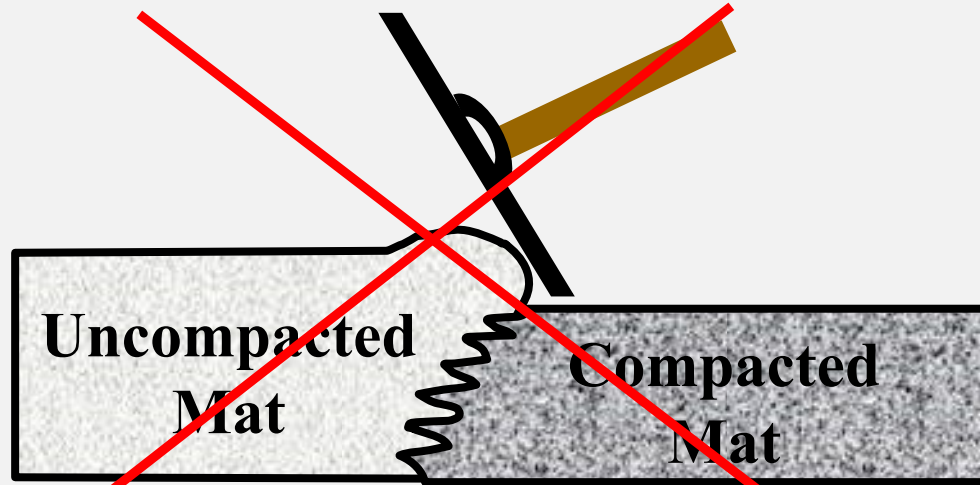

Do not Bump Mix Back to Joint

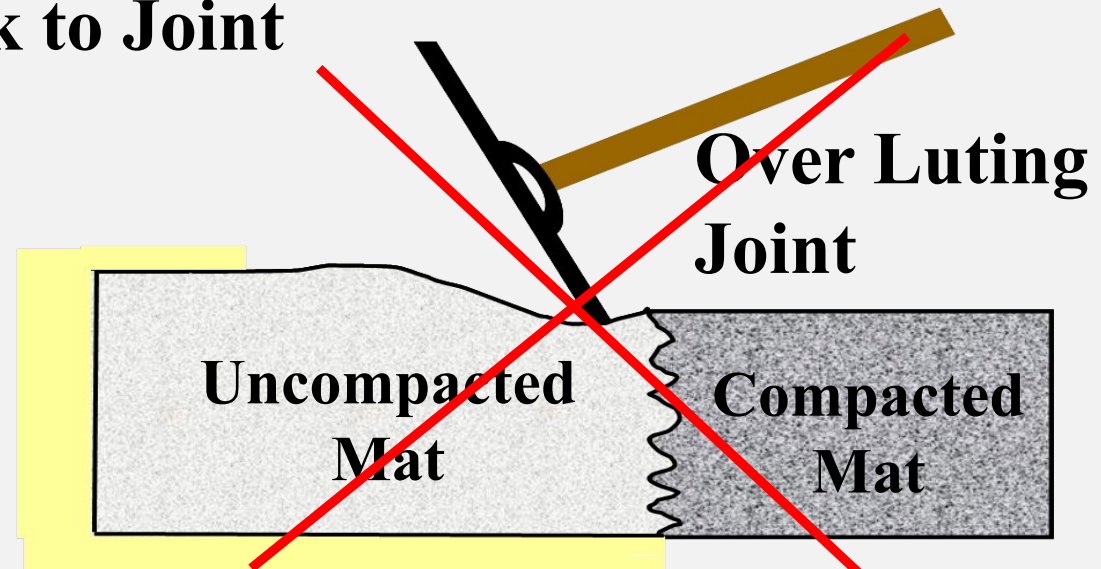

Do not 'cast' mix back over mat

If too large an overlap occurs...

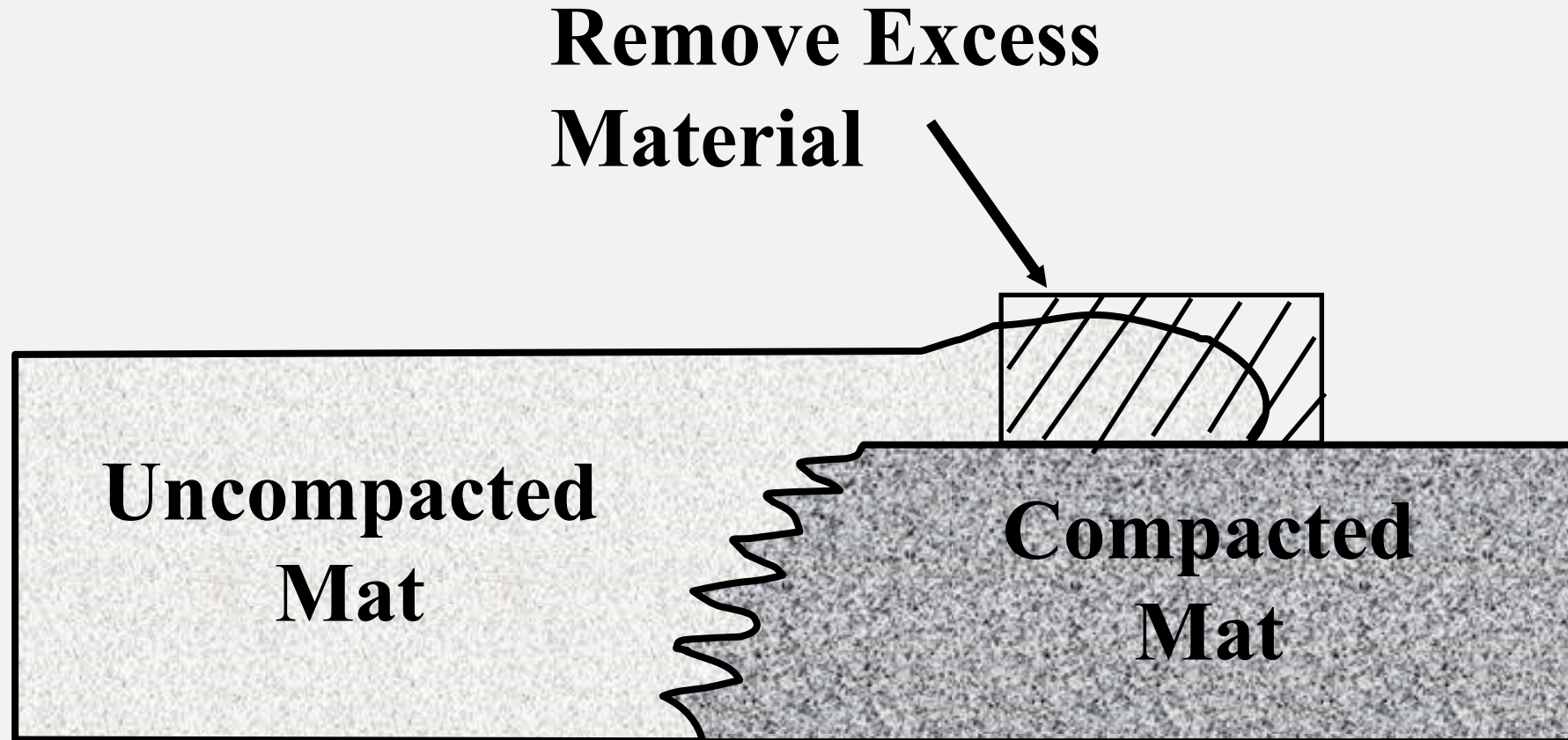

Bridging From Improper Overlap



Section 413.3(k): Joint Construction

- **(k) Joints**

- **Transverse Joints**

- Perpendicular to centerline
- Use temporary bulkheads or saw joint
- Paint joint face with PG binder in mix or PG 64-22.

- **Other Joints**

- Seal joint for new wearing course abutting existing pavement; apply min 6 inches on both sides of joint, using PG binder in mix, PennDOT Material Class Tack or NTT/CNTT.

Longitudinal Joint Construction

PennDOT/PAPA Training Video

Watch the Video



Recap of Video

- Plan ahead to avoid joints whenever possible
- **Offset joints 6”** from previous layer
- TACK must be **6” wider** than pavement
- First Pass **MUST** be straight
- Overhang Roller **3-6”** on unsupported edge

Recap of Video –Second Pass

- Lightly coat entire surface of NWJ or vertical joint with **64S-22** or asphalt binder in the mix
- Paver should overlap previous lane by **1-1/2 inches**
- Depth of overlap should match rolldown
- **NO LUTING or RAKING**

Recap of Video –Second Pass Compaction

- Compact from edge toward joint
- Leave **about 18 inches** of uncompacted material at NWJ
- Last pass overlaps Longitudinal joint **by 2-6 inches**
- Joint must receive as many passes as the rest of the mat

Section 460

Asphalt Tack Coat

Section 460

Asphalt Tack Coat

- **Work**
 - Conditioning & treating of an existing surface with an application of bonding material

- **Material**

Class of Material	Type of Material	Application Temperature °F	
		Minimum	Maximum
TACK	Anionic or Cationic Emulsified Asphalt	90	150
NTT/CNTT	Anionic or Cationic Emulsified Asphalt	140	180

Section 460

Asphalt Tack Coat

- **Construction**

- Asphalt distributor capable to apply material within a tolerance of 0.02 gal/sq yd, up to 15' wide.
- Hand-spraying equipment for inaccessible areas.
- Distributor's application rate to be determined using **PTM 747**.
- Apply tack only when **air temperature is 40°F and rising** and the surface is dry.
- Test section for each course to determine coverage and uniformity
- Tack to be **6 inches wider** than paving panel on BOTH sides
- Tack to “break” before being disturbed or start of paving

Tack Coat Inspection

- Road must be CLEAN and DRY (broom alone may not be enough).
- Obtain % Asphalt from BOL.
- Calculate the required application rate: Sec. 460, Table B.
- Apply 100-ft MINIMUM test strip 6” beyond longitudinal joint (s).
- Adjust bar height, pressure, and nozzles to ensure 100% uniform coverage.
- DO NOT begin paving until an acceptable test strip has been demonstrated
- Allow the tack coat to break and set and ensure that tracking has been minimized

Section 460 – TABLE B

Uniform Asphalt Residual Rates by Surface Type

Surface Type	Uniform Asphalt Residual Rates (RR) (gallons per square yard)
New Asphalt Paving	0.03 to 0.05
Existing Asphalt Paving	0.04 to 0.07
Milled Surface (Asphalt & Portland Cement Concrete)	0.04 to 0.08
Portland Cement Concrete	0.04 to 0.07

Review application/residue rates at Pre-Placement Meeting

Section 460

Asphalt Tack Coat

Etnyre Spray Bar Nozzles

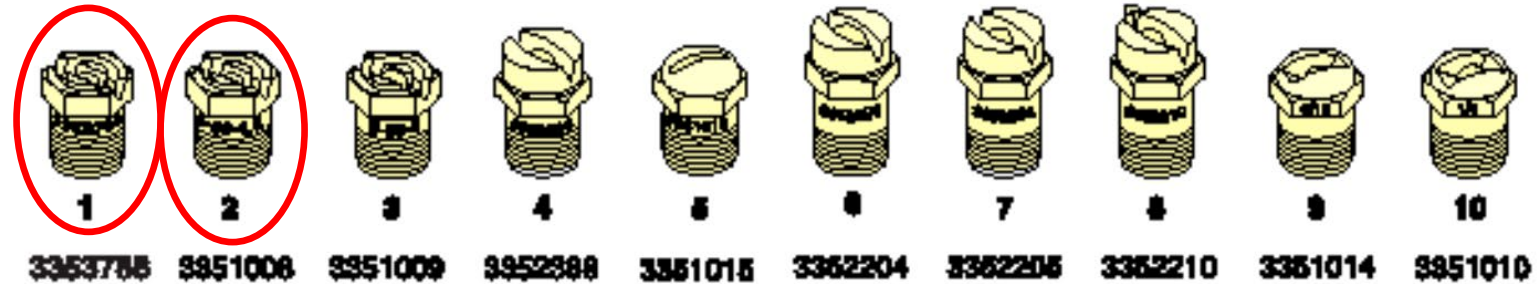

Ref.	Part No.	Description	Application Gallons Per Square Yard	Application (Metric) Liters Per Square Meter	US Flow Gallons Per Minute Per Foot
1	3353788	V Slot Tack Nozzle	.05 - .20	.23 - .91	3.0 to 4.5
2	3351008	S36-4 V Slot	.10 - .35	.45 - 1.58	4.0 to 7.5
3	3351009	S36-5 V Slot	.18 - .45	.81 - 2.04	7.0 to 10.0
4	3352368	Multi-Material V Slot	.15 - .40	.68 - 1.81	6.0 to 9.0
5	3351015	3/32" Coin Slot	.15 - .40	.68 - 1.81	6.0 to 9.0
6	3352204	Multi-Material V Slot	.35 - .95	1.58 - 4.30	12.0 to 21.0
7	3352205	Multi-Material V Slot	.20 - .55	.91 - 2.49	7.5 to 12.0
8	3352210	End Nozzle (3352205)	.20 - .55	.91 - 2.49	7.5 to 12.0
9	3351014	3/16" Coin Slot	.35 - .95	1.58 - 4.30	12.0 to 21.0
10	3351010	1/4" Coin Slot	.40 - 1.10	1.81 - 4.98	15.0 to 24.0

Application Rate Calculation for TACK or NTT/CNTT Emulsion

Example Calculation:

Required Tack coat = **0.04 gal/sq. yd.** for *Residue*

CNTT 0.67% Asphalt Residue (i.e., **asphalt content** from Bill of Lading)

1 gal of CNTT = 2/3 asphalt (67%) and 1/3 water (33%)

To determine the application rate, divide the required residue by asphalt content:

AR (Application Rate) = required residue ÷ asphalt content as a decimal

0.04 ÷ 0.67 = 0.059 (0.06) gal/sq. yd. of emulsion *application rate*

Check: 0.06 X 0.67 = 0.04 residue

Note: Asphalt content must be obtained from the Bill of Lading

PennDOT Surface Prep Training Module

- **WATCH THE VIDEO**

A video thumbnail with a dark asphalt background. The text "Asphalt Paving Surface Preparation" is written in large, white, bold, sans-serif font. At the bottom, there are several diagonal orange and yellow stripes. A white play button icon is centered over the stripes.

**Asphalt Paving
Surface Preparation**

Section 483
Polymer-Modified Emulsified
Asphalt Paving System
(Micro Surfacing)

Section 483

Micro Surfacing

- **Work**
 - construction of a polymer modified emulsified asphalt paving system commonly known as micro-surfacing, to fill ruts and/or resurface existing pavements.
- **Three mix types of micro-surfacing:**
 - **Type A.** Used to seal cracks, fill voids and shallow ruts (<1/2 inch) & provide a scratch course or surface seal.
 - **Type B.** Used to fill moderate ruts (1/2 to 1¼ inch) & provide a scratch course, a leveling course, a seal coat, or surface course
 - **Type Rut fill (RF).** Used to fill deep ruts (up to 2 inch) in a single pass

Note: Type A and Type B can use a double application when specified, to meet total design pounds per square yard for surface courses.

Section 483 Micro Surfacing



Section 483

Micro Surfacing

- **Construction**
 - **(f) Conditioning of Existing Surface. Section 409.3(g)1 & as follows:**
 - Clean surface immediately before placing material
 - **Remove all pavement markings & legends**
 - For existing concrete surfaces, apply tack coat (Section 460).
 - Do not apply tack coat on existing asphalt surfaces
 - **Apply water to dampen entire surface** immediately before placing mixture

Remove Pavement Markings



Micro Surfacing General Requirements

- If mix is NOT set up **within one hour**, the Dept. representative shall issue a warning to the contractor who may proceed with adjustments to ensure the one hour set up. If the material is not set up in **1hr and 20 minutes**, stop the application and remove and replace the failed material.

Section 483

Micro Surfacing

- Applied as a Mixture
- Polymers & Other Additives
- Lower Cost Compared to Overlay
- Relatively Long Service Life (4 to 7 yrs.)



- Specialized Equipment Needed

Microsurfacing

Purpose:

- Improve surface friction
- Fill ruts/minor surface irregularities
- Seal pavement surface



- **Designed to be open to traffic in 1 hour**

Section 489

Ultra Thin Bonded Wearing Course (UTWC)

- Plant mixed *UTWC*
- Do not apply **from Nov. 1 to Mar. 31** if binder is PG 64S-22
- Do not apply **from Oct. 15 to Mar. 31** if binder is PG 64E-22
- Do not place if surface wet or air or surface temperature is **below 50°F**
Paver with built-in spray bar, *UTWCEM* applied within 5 seconds of *UTWC*
- Roll without vibration at **185°F or greater** (vibes may be used on joint)
- May use pneumatic tire roller
- Cracks sealed at least 24 hours prior

UTWCEM: Polymer modified emulsified asphalt membrane for UTWC

Section 489

Ultra Thin Bonded Wearing Course (UTWC)

Type	NMAS	Placement Rates (pounds per square yard)
A	6.3 mm (1/4 inch)	45 to 65
B	9.5 mm (3/8 inch)	55 to 80
C	12.5 mm (1/2 inch)	60 to 85

Section 489

Ultra Thin Bonded Wearing Course



Section 489

Ultra Thin Bonded Wearing Course



Warm Mix Technologies

Warm Mix Asphalt

- A generic term for various technologies allowing asphalt paving materials to be produced and placed at lower temperatures.



Viscosity /Temperature Relationship

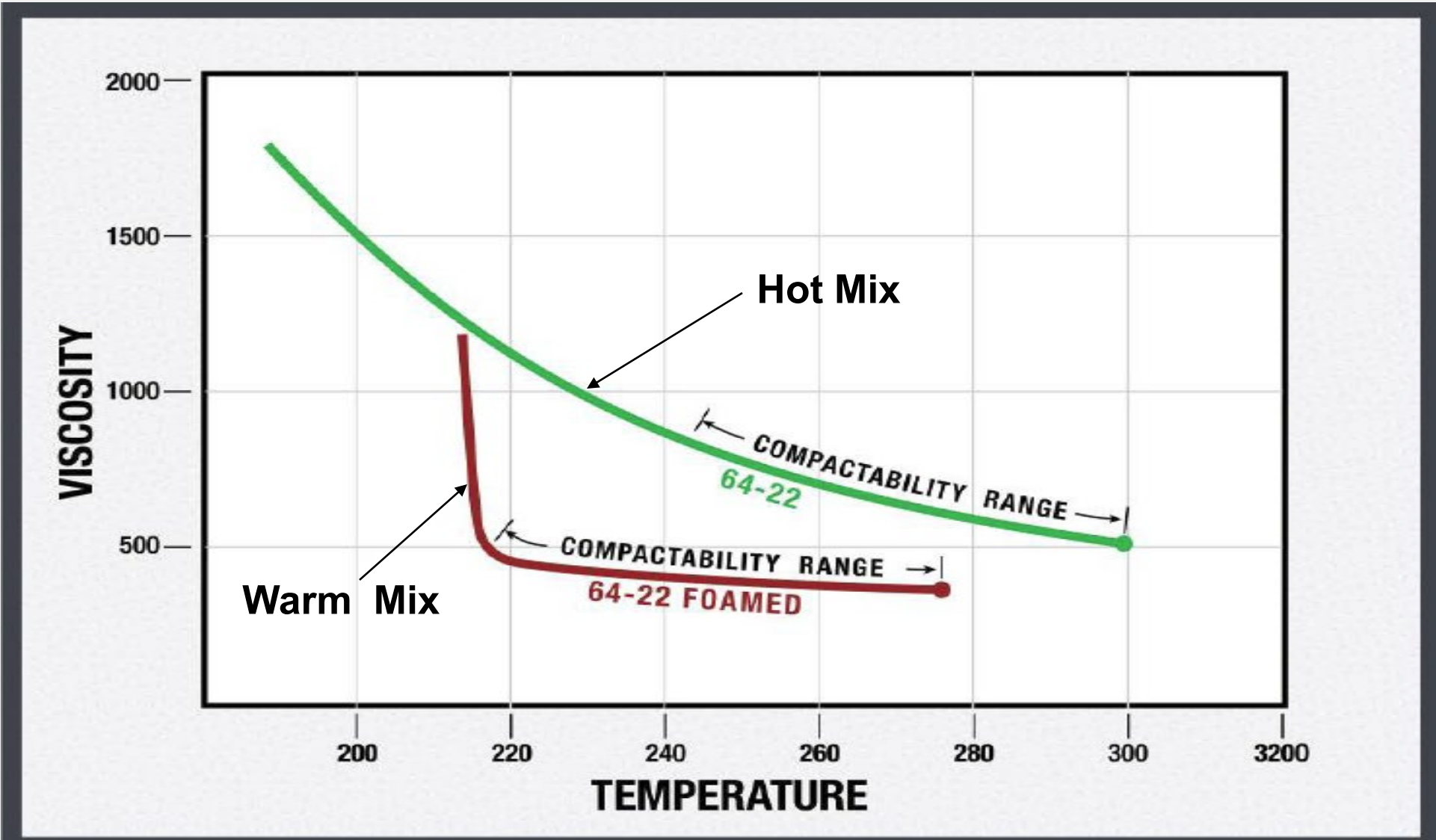

VISCOSITY / TEMPERATURE PG 64 -22 (Approx.)

What are WMA Technologies?

Broken down into 3 classes:

- Foaming Processes (Water)
- Chemical Additives (Emulsions)
- Organic (Wax)

Organic Additives

- May be liquid or pellets
- May be pre-blended or added at plant to liquid binder
- May be introduced at the mixing drum
- Usually minor plant modifications to batch or drum plant.

Chemical Additives or Surfactants

- May be added at refinery or WMA plant directly to liquid asphalt.
- Can be teamed with foaming process
- Usually minor, if any, plant modifications required.

Foaming Process

- Water and perhaps other additives
- Water may be contained in the additive
- May be injected into supply line or added to drum or pug mill
- Plant modification involves installation of additional equipment
- 1 quart of water/ ton of mix (approx.)

Safety Edge Requirements From FHWA

- Affects both Binder and wearing courses $>1 \frac{1}{2}$ inches
- Requires extrusion device at edge of pave (not just a strike-off)
- Incidental to course being laid
- 26-40 degree increase in angle from adjacent pavement.
- May require additional pre work

Note:

Drawings for this are in handouts. This cannot be laid on organic material and will be used in conjunction with shoulder back-up.

Adjustable Safety Edge Device







Summary (Part 2)

- **Discussed key elements of several Spec sections:**
 - **404** Evaluation of Asphalt Pavement Ride Quality and Payment of Incentive
 - **405** Evaluation of Asphalt Pavement Longitudinal Joints Density and Payment of Incentive/Disincentive
 - **413** Superpave Mixture Design, Standard & RPS Construction (The Part on Discussion of Joints)
 - **460** Asphalt Tack Coat
 - **483** Polymer-Modified Emulsified Asphalt Paving System (Micro Surfacing)
 - **489** Ultra Thin Bonded Wearing Course

Recap of Asphalt Construction

WATCH PAPA/PENNDOT VIDEO

Asphalt Laydown



Asphalt Construction Program

Certified Asphalt Field Technician Superpave: An Overview

N
E
C
E
P
T

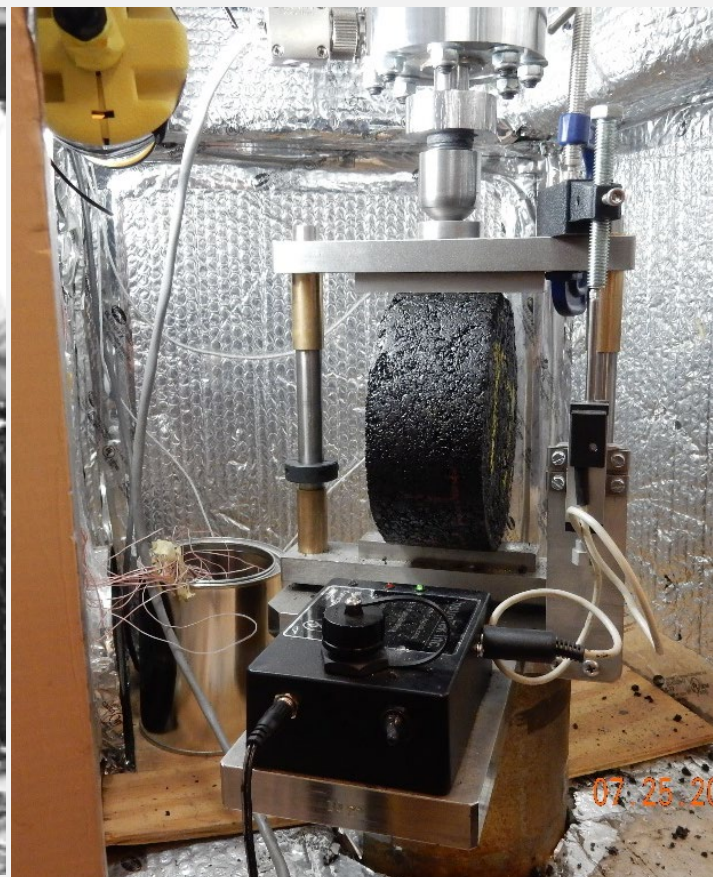
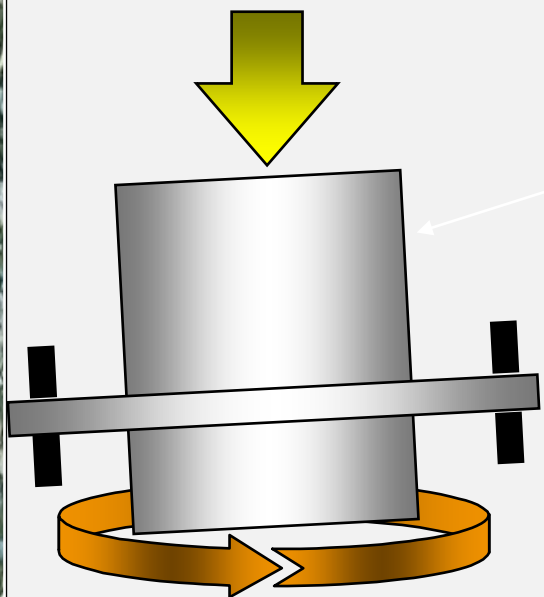

Topics We Will Review:

- **Major Pavement Distresses**
- **Superpave System to Address Distresses**
- **Superpave Binder Performance Grade (PG)**
- **Aggregate Requirements in Superpave**
- **Determination of Traffic Levels: ESALs**
- **Superpave Mix Sizes (Max. Agg. Size vs. Nominal Max. Agg. Size)**
- **Job Mix Formula (JMF) and Theoretical Max. Sp. Gr. of Mix (G_{mm})**

Problems with Asphalt Mixture Behavior

- **Permanent Deformation**
- **Low Temperature Cracking**
- **Fatigue Cracking**

**brought research leading to
Superpave technology**

Superior PERforming asphalt PAVEments

- Durability & Crack Resistance

- High quality asphalt binder
- Adequate asphalt film thickness around aggregate
(Asphalt Content)

- Rutting Resistance

- High content of crushed aggregate
- Stone-on stone contact
- High Modulus Asphalt

Resist Low Temperature (Shrinkage) Cracking

- Environmentally Induced Distress
 - Stresses Induced by Temperature Change
 - Pavement tends to shrink
 - Transverse Cracks
-
- Low temperature crack resistance:
 - Use Performance Grade (PG) binders
 - Binder meets performance requirements for low pavement temperature

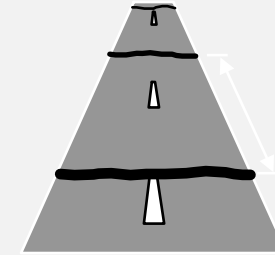

Resist Fatigue Cracking

- **Fatigue cracking in Wheel path**
- **Progressive Damage**
 - longitudinal cracking
 - alligator cracking
 - Potholes
- **Fatigue crack resistance:**
 - Binder meets performance requirements for **intermediate pavement temperature**
 - Increase binder content

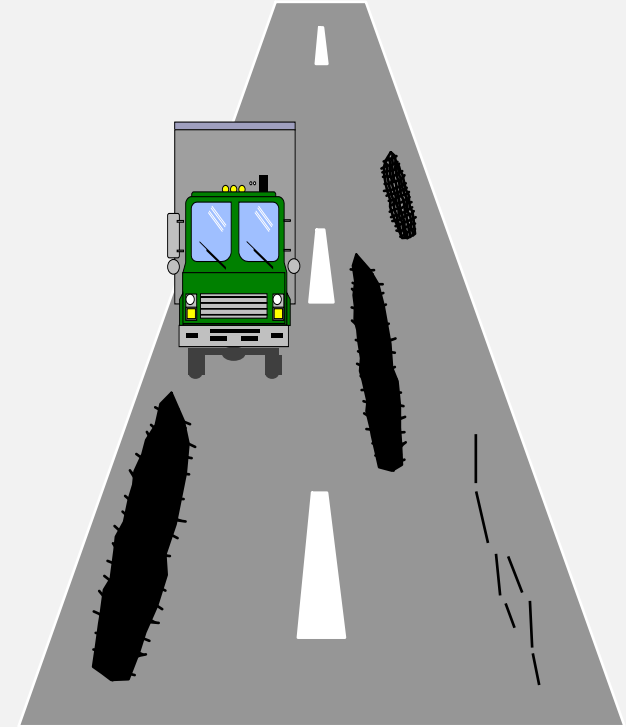

Resist Rutting

- Rutting in Wheel path
- Progressive Damage

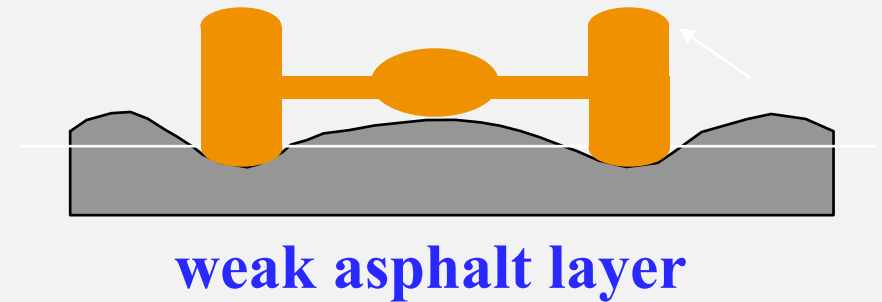
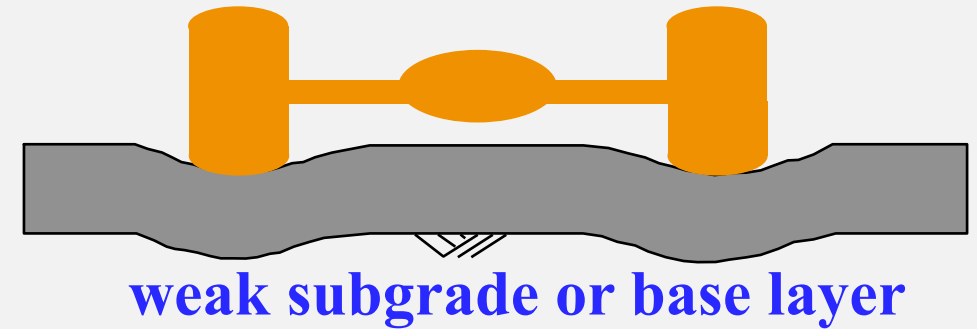

- Rutting resistance:

- Binder meets performance requirements for high pavement temperature
- High percent of crushed aggregate
- Stone-to-stone contact



Rutting

Superpave Asphalt Binder Specification

- Grading System Based on Climate

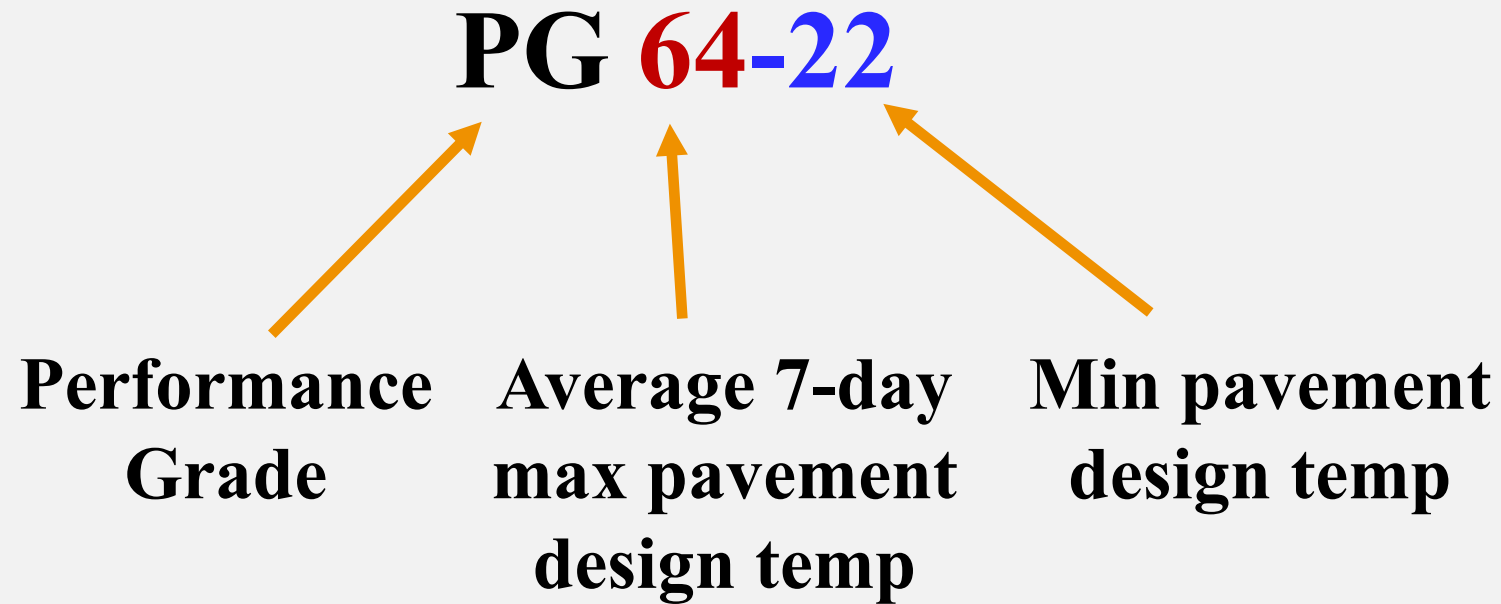

Superpave Asphalt Binder Specification (AASHTO M 320)

- **Grades available**

3 Standard Performance Grade (PG) Binders

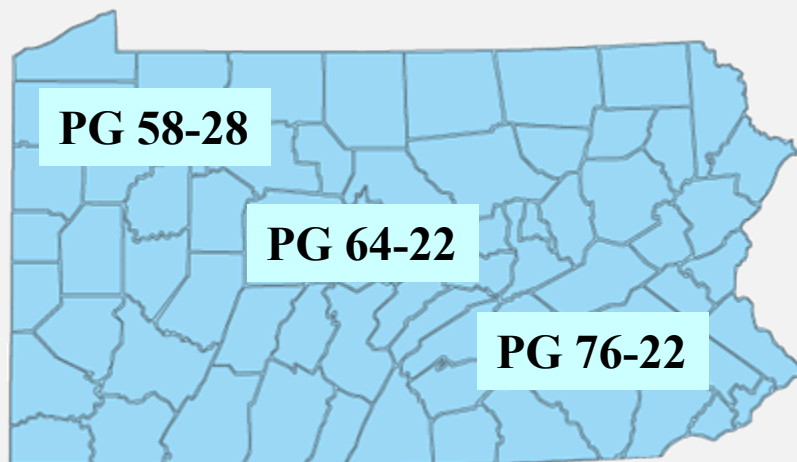

PG 58-28 \approx AC - 10

PG 64-22 \approx AC - 20

PG 76-22 \approx Polymer
Modified Asphalt Cement for
High Traffic Volume Highways

**Note: Other grades available per PennDOT special provision*

PennDOT MSCR Specification (AASHTO M 332)

PennDOT has now moved to AASHTO M 332 Specification

Traffic Level (million ESAL)	J _{nr} @ 3.2 KPa Stress Test Temp. = 64°C	Binder Grade
< 3	< 4.5	Standard (S)
>3 and < 10	< 2.0	Heavy (H)
>10 and < 30	< 1.0	Very Heavy (V)
> 30	< 0.5	Extreme (E)

Determine J_{nr} (Creep Compliance)

PennDOT MSCR Specification (AASHTO M 332)

PennDOT has now moved to AASHTO M 332 Specification

AASHTO M 320 Grading	AASHTO M 332 Grading
PG 58-28	PG 58S-28
PG 64-22	PG 64S-22
PG 76-22	PG 64E-22

Superpave Mix Design Considers Essential Aggregate Properties

- **Remember: ROCK CARRIES THE LOAD**
- **Consensus Properties**
 - Coarse aggregate angularity (CAA)
 - Fine aggregate angularity (FAA)
 - Flat and elongated particles
 - Clay content
- **Source Properties**
 - Toughness (resistance to wear and tear under traffic load)
 - Soundness (resistance to weathering and climate effects)
 - Deleterious materials and detrimental clay

Superpave Specifications: ESALS

1 ESAL (Equivalent Single Axle Load) is 18,000 lbs.

- Asphalt Mix Design is based on Traffic Level.
- ESAL Levels are related to Traffic Levels.
- Truck traffic has huge impact on ESAL Levels.
- ESALs are used to determine the amount of asphalt in the mix.
- Important to have the right amount of asphalt to reduce rutting and cracking.

ESAL Comparison

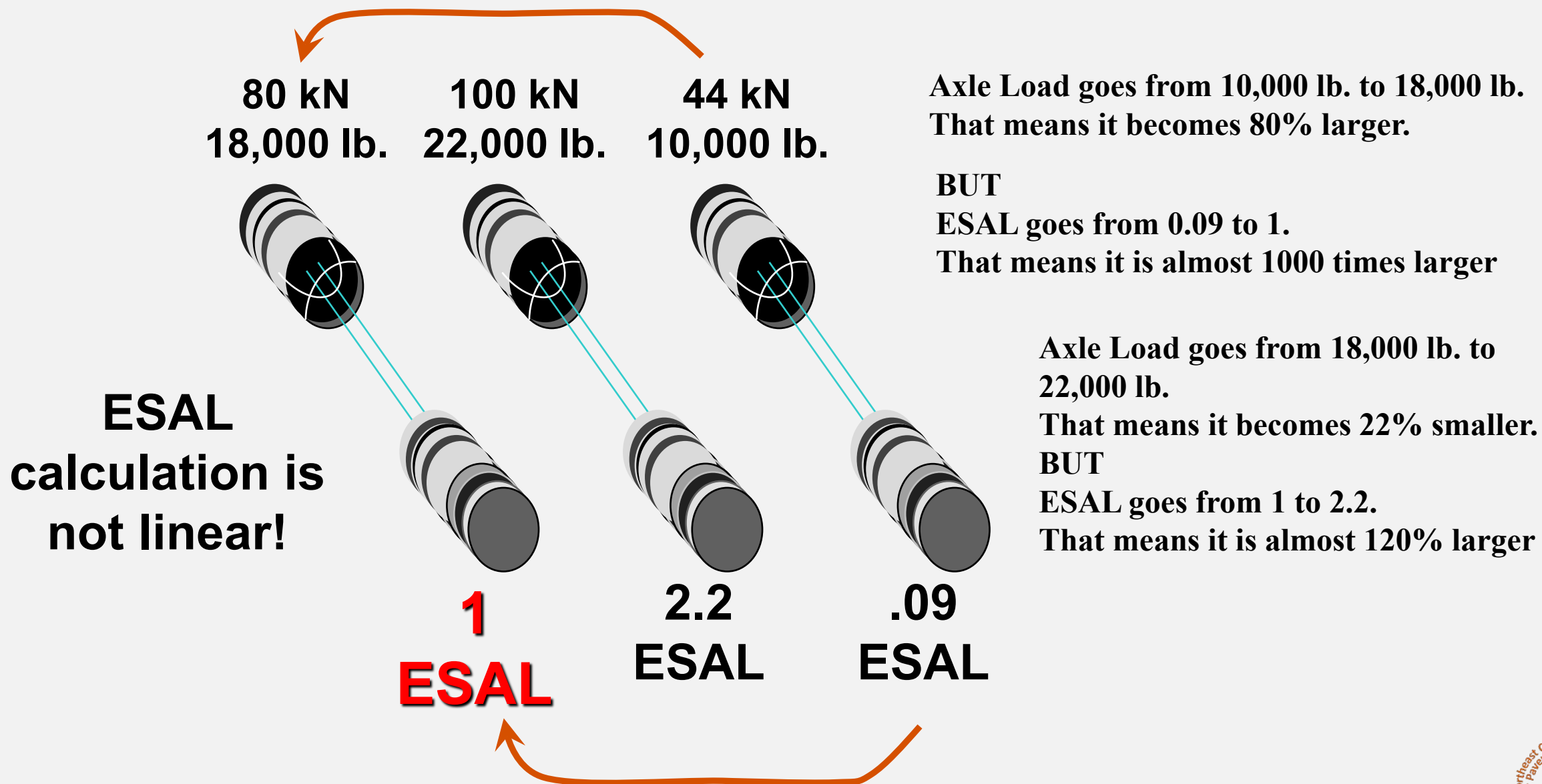

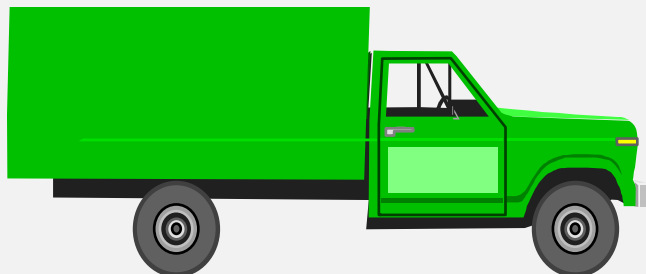

$$\begin{array}{rcl}
 67 \text{ kN} & & 27 \text{ kN} \\
 15,000 \text{ lb.} & + & 6,000 \text{ lb.} \\
 0.48 \text{ ESAL} & & 0.01 \text{ ESAL} \\
 & & = \mathbf{0.49 \text{ ESALs}}
 \end{array}$$

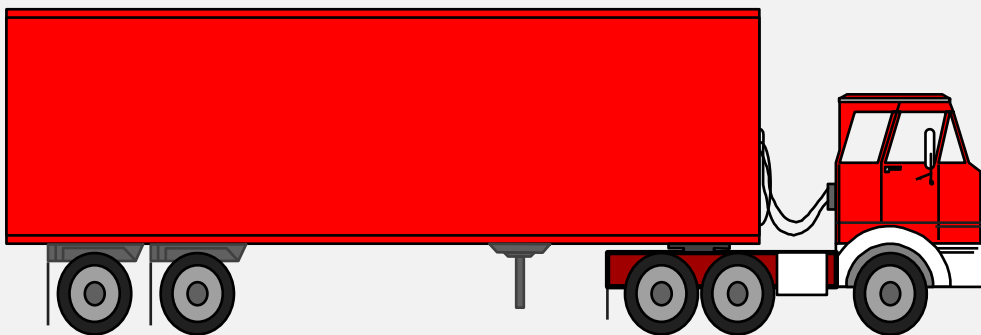

$$\begin{array}{rcl}
 151 \text{ kN} & & 151 \text{ kN} & & 54 \text{ kN} \\
 34,000 \text{ lb.} & + & 34,000 \text{ lb.} & + & 12,000 \text{ lb.} \\
 1.10 & & 1.10 & & 0.19 \\
 & & & & = \mathbf{2.39 \text{ ESALs}}
 \end{array}$$

ESAL Comparison

- In road design, for a 20-year pavement life:

One fully loaded tractor-trailer per day for 20 years:

$$= 2.39 \times 365 \times 20 \approx 17,450 \text{ ESALs}$$

(assumed 0% growth rate)

Typical ESAL ranges for Asphalt Mixes

▪ 0.0 – 0.3 million	~ 0 to 17 trucks	light
▪ 0.3 – 3.0 million	~ 17 to 172	medium
▪ 3.0 – 10.0 million	~ 172 to 573	high
▪ 10.0 – 30.0 million	~ 573 to 1720	heavy

ESALS?



www.StrangeCosmos.com

Off-Highway Two-Axle Power Train Haul Trucks (ESALs???)



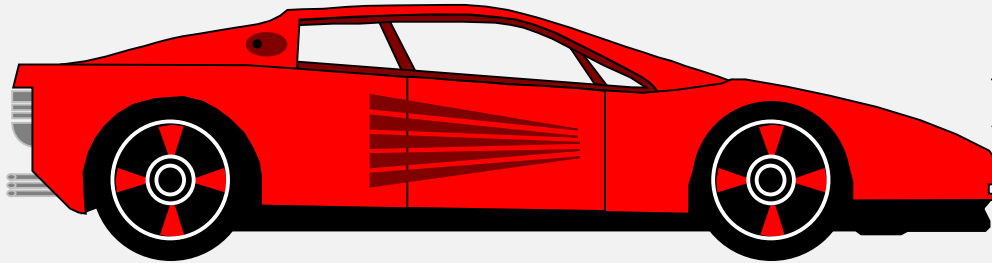

1 Auto = 0.0002 ESAL

1,000 lb.

.00001 ESAL

2,000 lb.

.00019 ESAL

1 Truck @ 2.39 ESALs = how many cars?

Ans: 11,950 Autos

Cars do not count much!!!!

ESALS?



Although Some Cars Can Also Be a Problem



Gradation Analysis and NMAS

Stack in Mechanical Shaker

Individual Sieve

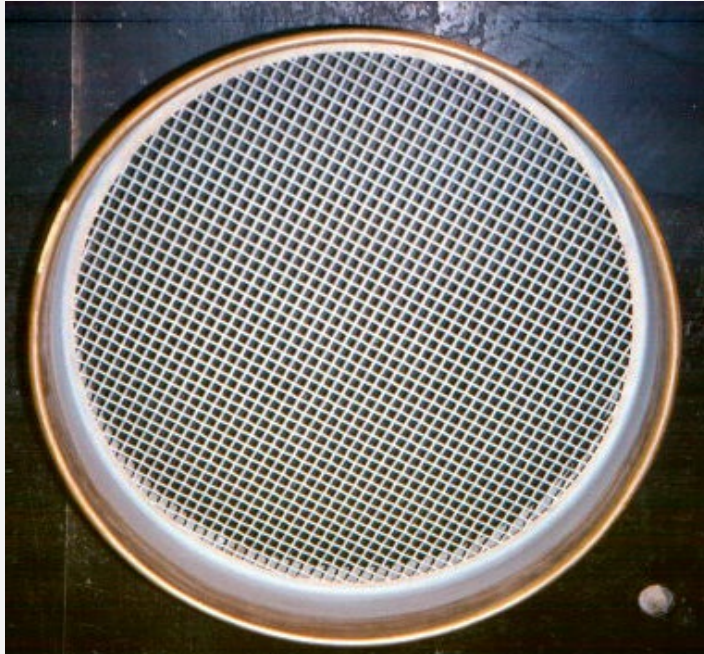

Superpave uses the Nominal Maximum Aggregate Size

Aggregate Size Definitions

▪ *Nominal Maximum Aggregate Size*

One size larger than the first sieve to retain more than 10% of the sample and is the “name” of the mix.

▪ *Maximum Aggregate Size*

One size larger than nominal maximum size

Max. Size vs Nominal Max. Agg. Size (NMAS)

Example:

Aggregate 1		Aggregate 2	
Sieve Size	% Passing	Sieve Size	% Passing
25 mm	100%	25 mm	100%
19 mm	100%	19 mm	98%
12.5 mm	92%	12.5 mm	87%
9.5 mm	72%	9.5 mm	72%

Max Sieve

Nom. Max. Sieve

Superpave Mixes: Size Designations

<u>Superpave Designation</u>	<u>Nominal Max Agg. Size mm (inches)</u>	<u>Max Agg. Size mm (inches)</u>
37.5 mm (1.5")	37.5 (1.5)	50.0 (2)
25.0 mm (1.0")	25.0 (1.0)	37.5 (1.5)
19.0 mm (3/4")	19.0 (3/4)	25.0 (1.0)
12.5 mm (1/2")	12.5 (1/2)	19.0 (3/4)
9.5 mm (3/8")	9.5 (3/8)	12.5 (1/2)
6.3 mm (1/4")	6.3 (1/4)	9.5 (3/8)
4.75 mm (1/5")	4.75 (1/5)	9.5 (3/8)

→ PennDOT

Layer Choices

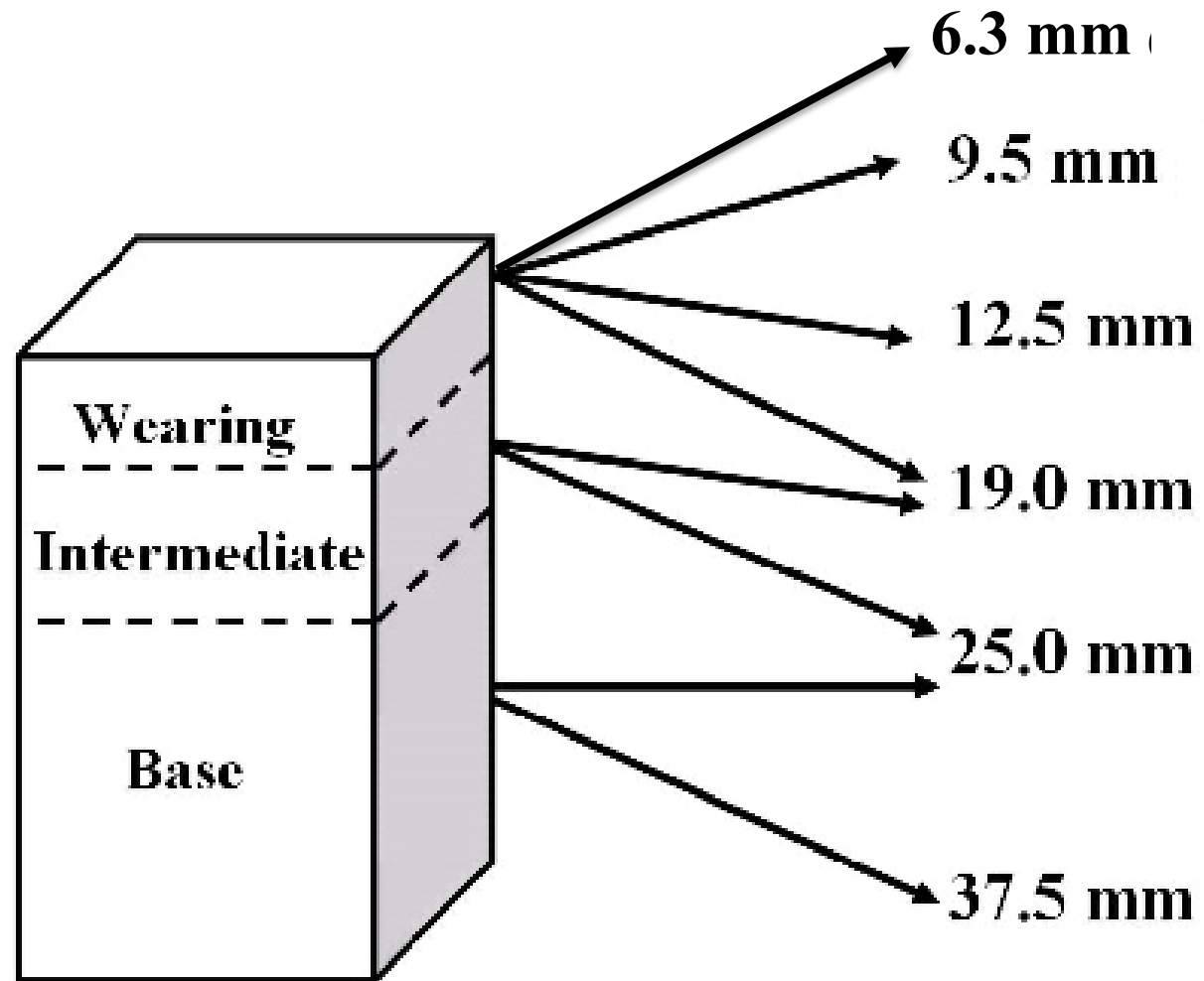

Superpave Mixes: Designations

- 1. BINDER GRADE (PG)**
- 2. DESIGN LOADING (ESALS)**
- 3. MIX SIZE (NMMAS)**
- 4. SKID RESISTANCE (SRI)**

Job-Mix Formula



Supplier **Pave, Inc**
 ECMS Number
 SR & Contractor

TR-448A (6-15) JOB MIX FORMULA REPORT
 PennDOT Mix Design Designation
 Year Number
 2015 5220R
 Supplier JMF/Design Number (Optional)

Supplier Code **pave 123**
 Material Class **SR25BC**
 Design ESAL Range **0.3 to < 3 Million**
 Aggregate Skid Resistance Level **Non-Applicable**
 Mixture Final Asphalt Binder Grade **PG6422**
 Asphalt Mix Type **HMA**
 Gradation Classification **Coarse-Graded**
 Original Approval Date
 JMF Status **Approved**

Location **anywhere**
 408 Spec
 Plant 10
 Dry(s) 5
 Wet(s) 35

Material Supplier	Material Code - Class	Product Name	%	Spec.	%
HAP41A14	207 (Aggregate Fine) - A	Sand A1	4.100	2.568	1.72
HAP41B14	207 (Aggregate Fine) - B3	B3 (W)	16.400	2.663	1.37
HAP41B14	203 (Aggregate) - A467	A467	17.400	2.724	0.89
HAP41B14	203 (Aggregate) - A57	A57	36.100	2.710	1.33
HAP41B14	203 (Aggregate) - A8	A8	7.300	2.698	1.27
NOBLT 14	17 (Hot Rap Design) - RAP	RAP	15.000	2.740	0.00
UNRC0 15	1 (Asphalt Cement) - PG6422	AC	3.700	1.031	

JOB MIX FORMULA AND DESIGN													
A.C. / Sieve Size	A.C%	#200	#100	#50	#30	#16	#8	#4	3/8"	1/2"	3/4"	1"	1 1/2"
Design Target	4.4	4.0	5	7	12	17	25	37	53	66	86	96	100
% Virgin A.C.		3.7		% Reclaimed A.C. from RAP		0.70		Total % Asphalt (Pb)		4.4			
Virgin A.C. PG Binder Grade		PG6422		% Reclaimed A.C. from RAS				% Eff. Asphalt Binder		4.1			

MIX CHARACTERISTICS (GYRATORY)							
Design ESAL Range	Mold Diameter (mm)	# Gyration at Ninitial	# Gyration at NDesign	# Gyration at NMaximum	Voids in Mineral Aggregate (VMA) %	Theoretical Max. Sp. Grav. (Gmm)	Bulk Sp. Grav. of Mixture (Gmb)
0.3 to < 3 Million	150	7	75	115	13.8	2.537	2.436
Bulk Sp. Grav. of Combined Aggr.(Gsb)	Mixture Mass to Compact (g)	% Air Voids at Ninitial	% Aid Voids at NDesign	% Air Voids at NMaximum	Voids filled with Asphalt (VFA) %	Theoretical Max. Density (lbs/ft3)	Bulk Density of Mixture (lbs/ft3)
2.701	4,740.0	14.5	4.0	2.6	71.0	157.9	151.6

ASPHALT CONTENT TEST METHOD						
A.C. Test Method	External Party Oven Make/Model	Furnace Temp (°C)	Sample Size for C.F.	Asphalt	200 C.F.	
PTM No. 757	Thermolyne/NCAT AP-20x	538.0	2,000.0	0.47	0.00	

MOISTURE SUSCEPTIBILITY DATA						
A.C. Supplier	Name	Dry PSI Strength	Wet PSI Strength	TSR Value	Date of TSR	Date of Boil Test
UNRC0 15	AC	103.7	100.4	0.99	11/29/05	11/29/05

COMBINED AGGREGATE CONSENSUS PROPERTIES						
AASHTO T 176 Sand Equivalency (%)	AASHTO T 304 Fine Aggr. Angularity Uncompacted Voids (%)	ASTM D5821 - Coarse Aggregate Angularity		ASTM D4791 Flat / Elongated Particles	Total % Reclaimed Agg. From RAP and / or RAS	
		% 1 Face Crush	% 2 Face Crush	5:1	3 SMA	
89.6	45.9	100.0	100.0	1.6		14.3

Designed By : designer
 Submitted By : submitter
 Approved By : approver

Designed By Certification ID : ROBIN
 Submitted By Certification ID : BATMAN
 Approved By Certification ID : Materials Engineer

Print ##### 7:47:45 AM

Page 1 of 1



Job-Mix Formula



MIX CHARACTERISTICS (GYRATORY)

Design ESAL Range	Mold Diameter (mm)	# Gyration at Ninitial	# Gyration at NDesign	# Gyration at NMaximum	Voids in Mineral Aggregate (VMA) %	Theoretical Max. Sp. Grav. (Gmm)	Bulk Sp. Grav. of Mixture (Gmb)
0.3 to < 3 Million	150	7	75	115	13.8	2.537	2.436
Bulk Sp. Grav. of Combined Aggr.(Gsb)	Mixture Mass to Compact (g)	% Air Voids at Ninitial	% Air Voids at NDesign	% Air Voids at NMaximum	Voids filled with Asphalt (VFA) %	Theoretical Max. Density (lbs/ft3)	Bulk Density of Mixture (lbs/ft3)
2.701	4,740.0	14.5	4.0	2.6	71.0	157.9	151.6

Note:

Theoretical Max. Density = 62.245 X Theoretical Max. Sp. Gr.

That Is: 157.9 = 62.245 X 2.537

What does 62.245 represent? It is density of water in pounds per cubic feet (pcf).

157.9 is the number we enter into the nuclear gauge for field density measurement.

157.9 is also the base number we use to determine the field yield density.

Summary

- **Major Pavement Distresses (Rutting, Fatigue Cracking, Low Temperature Cracking)**
- **Superpave System was developed to address pavement distresses**
- **Superpave Binder Performance Grade (PG) – Pavement Temperature & Traffic**
- **Determination of Traffic Level: ESALs**
- **Superpave Mix Sizes (Max. Agg. Size vs. Nominal Max. Agg. Size)**
- **Job Mix Formula and Max. Sp. Gr. of Mix**

Asphalt Construction Program

Certified Asphalt Field Technician

Determining Lots/Sublots and Sample Locations



Determining Lots & Sublots, and Sampling Locations

Contents:

- Table D (Section 413.3(h)2.a Lots & Sublots)
- PTM 1, Table 1, Random Number Table
- Problem 1 Parts A, B, C, D
- Problem 2 Parts A,B
- Problem 3
- Problem 4

Three Major Rules

- 1 2500 TON OR MORE OF ANY JMF PER PROJECT:
DIVIDE BY 500 TONS AND ROUND UP TO DETERMINE THE NUMBER OF SUBLOTS
- 2 >500 TON BUT < 2500
DIVIDE INTO 5 EQUAL SUBLOTS
- 3 500 TON OR LESS
DIVIDE INTO 3 EQUAL SUBLOTS

413.3(h)2.a Lots and Sublots: Table D

Re-adjustment of Lot Size & Associated Number of Sublots

Remaining Quantity* Following Last Full Lot	Action
Less than 500 tons <u>without</u> a combination of one mixture acceptance sample and one core	Quantity combined with previous lot, (n=5)
Less than 500 tons <u>with</u> a combination of one mixture acceptance sample and one core	One new subplot defined & quantity combined with previous lot, (n=6)
500 tons to less than 1000 tons <u>without</u> a combination of two mixture acceptance samples and two cores	One new subplot defined & quantity combined with previous lot, (n=6)
500 tons to less than 1000 tons <u>with</u> a combination of two mixture acceptance samples and two cores	Two new sublots defined & quantity combined with previous lot, (n=7)
1000 tons to less than 1500 tons <u>without</u> a combination of three mixture acceptance samples and three cores	Two new sublots defined & quantity combined with previous lot, (n=7)
1000 tons to less than 1500 tons <u>with</u> a combination of three mixture acceptance samples and three cores	New lot defined, (n=3)

Remaining Quantity* Following Last Full Lot	Action
1500 tons to less than 2000 tons <u>without</u> a combination of four mixture acceptance samples and four cores	New lot defined, (n=3)
1500 tons to less than 2000 tons <u>with</u> a combination of four mixture acceptance samples and four cores	New lot defined, (n=4)
2000 tons to less than 2500 tons <u>without</u> a combination of five mixture acceptance samples and five cores	New lot defined, (n=4)
2000 tons to less than 2500 tons <u>with</u> a combination of five mixture acceptance samples and five cores	New lot defined, (n=5)

PennDOT

TABLE I

RANDOM POSITIONS IN DECIMAL FRACTIONS (2 PLACES)

	X	Y		X	Y		X	Y
1.	0.29	R 0.66	34.	0.61	L 0.87	67.	0.93	R 0.17
2.	0.74	R 0.49	35.	0.76	R 0.16	68.	0.40	R 0.50
3.	0.89	L 0.79	36.	0.87	L 0.10	69.	0.44	R 0.15
4.	0.60	R 0.39	37.	0.41	L 0.10	70.	0.03	L 0.60
5.	0.88	R 0.31	38.	0.28	R 0.23	71.	0.19	L 0.37
6.	0.72	L 0.54	39.	0.22	L 0.18	72.	0.92	L 0.45
7.	0.12	R 0.08	40.	0.21	L 0.94	73.	0.20	L 0.85
8.	0.09	L 0.94	41.	0.27	L 0.52	74.	0.05	R 0.56
9.	0.62	L 0.11	42.	0.39	R 0.91	75.	0.46	R 0.58
10.	0.71	R 0.59	43.	0.57	L 0.10	76.	0.43	R 0.91
11.	0.36	L 0.38	44.	0.82	L 0.12	77.	0.97	L 0.55
12.	0.57	R 0.49	45.	0.14	L 0.94	78.	0.06	R 0.51
13.	0.35	R 0.90	46.	0.50	R 0.58	79.	0.72	L 0.78
14.	0.69	L 0.63	47.	0.93	L 0.03	80.	0.95	L 0.36
15.	0.59	R 0.68	48.	0.43	L 0.29	81.	0.16	L 0.61
16.	0.06	L 0.03	49.	0.99	L 0.36	82.	0.29	R 0.47
17.	0.08	L 0.70	50.	0.61	R 0.25	83.	0.48	R 0.15

18.	0.67	L 0.68	51.	0.87	L 0.36	84.	0.73	R 0.64
19.	0.83	R 0.97	52.	0.34	L 0.19	85.	0.05	L 0.94
20.	0.54	R 0.58	53.	0.37	R 0.33	86.	0.43	L 0.05
21.	0.82	R 0.50	54.	0.97	L 0.79	87.	0.87	R 0.98
22.	0.66	R 0.73	55.	0.13	R 0.56	88.	0.37	L 0.71
23.	0.06	L 0.27	56.	0.85	R 0.64	89.	0.94	L 0.26
24.	0.03	L 0.13	57.	0.14	L 0.04	90.	0.57	L 0.63
25.	0.55	L 0.29	58.	0.99	R 0.74	91.	0.26	R 0.80
26.	0.64	L 0.77	59.	0.40	L 0.76	92.	0.01	L 0.79
27.	0.30	R 0.57	60.	0.37	L 0.09	93.	0.83	R 0.59
28.	0.51	R 0.67	61.	0.90	R 0.74	94.	0.71	L 0.21
29.	0.29	R 0.09	62.	0.09	L 0.70	95.	0.65	L 0.63
30.	0.63	R 0.82	63.	0.66	L 0.97	96.	0.65	L 0.87
31.	0.53	L 0.86	64.	0.89	L 0.55	97.	0.72	R 0.92
32.	0.99	R 0.22	65.	0.67	L 0.44	98.	0.85	L 0.78
33.	0.02	R 0.89	66.	0.02	R 0.65	99.	0.04	L 0.46
						100.	0.29	L 0.95

X = Decimal fraction of the total length measured along the road from the starting point.

Y = Decimal fraction measured across the road from either outside edge towards the centerline of the paved lane.

R = Indicates measurement from the right edge of the paved lane.

L = Indicates measurement from the left edge of the paved lane.

Job-Mix Formula



Supplier **Pave, Inc**
 ECMS Number
 SR &
 Contractor

TR-448A (6-15) JOB MIX FORMULA REPORT
 PennDOT Mix Design Designation
 Year Number
 2015 5220R
 Supplier JMF/Design Number (Optional)

Supplier Code
 pave 123
 Material Class
 SR25BC
 Design ESAL Range 0.3 to < 3 Million
 Aggregate Skid Resistance Level Non-Applicable
 Mixture Final Asphalt Binder Grade PG6422
 Asphalt Mix Type HMA
 Gradation Classification Coarse-Graded
 Original Approval Date
 JMF Status Approved

Supplier	Pave, Inc	Location	anywhere	408 Spec	Mix Time
ECMS Number	PO No.-Line Item No.	Plant Type	AB	Plant	Dry(s) Wet(s)
				10	5 35
Material Supplier	Material Code - Class	Product Name	%	Spec.	%
HAP41A14	207 (Aggregate Fine) - A	Sand A1	4.100	2.568	1.72
HAP41B14	207 (Aggregate Fine) - B3	B3 (W)	16.400	2.663	1.37
HAP41B14	203 (Aggregate) - A467	A467	17.400	2.724	0.89
HAP41B14	203 (Aggregate) - A57	A57	36.100	2.710	1.33
HAP41B14	203 (Aggregate) - A8	A8	7.300	2.698	1.27
NOBLT 14	17 (Hot Rap Design) - RAP	RAP	15.000	2.740	0.00
UNRC0 15	1 (Asphalt Cement) - PG6422	AC	3.700	1.031	

JOB MIX FORMULA AND DESIGN													
A.C. / Sieve Size	A.C%	#200	#100	#50	#30	#16	#8	#4	3/8"	1/2"	3/4"	1"	1 1/2"
Design Target	4.4	4.0	5	7	12	17	25	37	53	66	86	96	100
% Virgin A.C.		3.7							0.70				Total % Asphalt (Pb) 4.4
Virgin A.C. PG Binder Grade		PG6422											% Eff. Asphalt Binder 4.1

MIX CHARACTERISTICS (GYRATORY)							
Design ESAL Range	Mold Diameter (mm)	# Gyration at Ninitial	# Gyration at NDesign	# Gyration at NMaximum	Voids in Mineral Aggregate (VMA) %	Theoretical Max. Sp. Grav. (Gmm)	Bulk Sp. Grav. of Mixture (Gmb)
0.3 to < 3 Million	150	7	75	115	13.8	2.537	2.436
Bulk Sp. Grav. of Combined Aggr.(Gsb)	Mixture Mass to Compact (g)	% Air Voids at Ninitial	% Air Voids at NDesign	% Air Voids at NMaximum	Voids filled with Asphalt (VFA) %	Theoretical Max. Density (lbs/ft3)	Bulk Density of Mixture (lbs/ft3)
2.701	4,740.0	14.5	4.0	2.6	71.0	157.9	151.6

ASPHALT CONTENT TEST METHOD						
A.C. Test Method	External Party Oven Make/Model	Furnace Temp (°C)	Sample Size for C.F.	Asphalt	200 C.F.	
PTM No. 757	Thermolyne/NCAT AP-20x	538.0	2,000.0	0.47	0.00	

MOISTURE SUSCEPTIBILITY DATA						
A.C. Supplier	Name	Dry PSI Strength	Wet PSI Strength	TSR Value	Date of TSR	Date of Boil Test
UNRC0 15	AC	103.7	100.4	0.55	1/15/05	1/15/05

COMBINED AGGREGATE CONSENSUS PROPERTIES						
AASHTO T 176 Sand Equivalency (%)	AASHTO T 304 Fine Aggr. Angularity Uncompacted Voids (%)	ASTM D5821 - Coarse Aggregate Angularity % 1 Face Crush % 2 Face Crush		ASTM D4791 Flat / Elongated Particles 5:1 3 SMA	Total % Reclaimed Agg. From RAP and / or RAS	
89.6	45.9	100.0	100.0	1.6	14.3	

Designed By : designer
 Submitted By : submitter
 Approved By : approver
 Print ##### 7:47:45 AM

Designed By Certification ID : ROBIN
 Submitted By Certification ID : BATMAN
 Approved By Certification ID : Materials Engineer

Designed 4/1/11
 Submitted 7/21/15
 Approved 7/21/15

Page 1 of 1



Job-Mix Formula

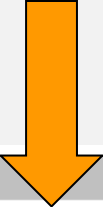

MIX CHARACTERISTICS (GYRATORY)							
Design ESAL Range	Mold Diameter (mm)	# Gyration at Ninitial	# Gyration at NDesign	# Gyration at NMaximum	Voids in Mineral Aggregate (VMA) %	Theoretical Max. Sp. Grav. (Gmm)	Bulk Sp. Grav. of Mixture (Gmb)
0.3 to < 3 Million	150	7	75	115	13.8	2.537	2.436
Bulk Sp. Grav. of Combined Aggr.(Gsb)	Mixture Mass to Compact (g)	% Air Voids at Ninitial	% Air Voids at NDesign	% Air Voids at NMaximum	Voids filled with Asphalt (VFA) %	Theoretical Max. Density (lbs/ft3)	Bulk Density of Mixture (lbs/ft3)
2.701	4,740.0	14.5	4.0	2.6	71.0	157.9	151.6

How we get Theoretical Max. Density = **157.9** lbs/cu.ft.?

62.245 X the Theor. Max. Sp. Gr. (2.537) = 157.9

62.245 is density of water at 77°F.

Do not multiply the Gmm by 62.4 (old).

Enter 157.9 into the nuclear gauge.

Determining Lots & Sublots and Sampling Locations

Problem 1 :

- **Part A:** You are the inspector on a paving project using 1-½ inches of 9.5 mm wearing surface. The project calls for placing 3,745 tons for a 12-foot lane. You intend to take a combination of mixture acceptance and core samples. How many **SUBLOTS** will be involved?

How Many Sublots ?

- 3,745 tons > 2,500 So, **Use Rule #1**
- **DIVIDE BY 500 AND ROUND UP**
- $3,745 / 500 = 7.49$ OR **8 POSSIBLE sublots** to compute for sampling locations
- IF no paving delays > 5 days
- A subplot exists **ONLY** if you get both a loose and core sample

How Many Lots?

- We do not yet know how many Lots.
- LOT sizes are decided by actual paving schedules and Table D
- *Completed* lots must have 3 sublots (one loose mix sample and one core per subplot) and NEVER have more than 7 sublots

Problem 1 :

Part A: How many Lots and Sublots will be involved?

Answer:

- 3,745 tons
- 1st LOT = 2,500 TONS = 5 SUBLOTS @ 500 TONS each
- 3,745 tons – 2500 tons = 1,245 tons
- $1,245 \text{ tons} \div 500 = 2 \text{ complete}$ sublots from which you will get a combination of loose and core samples AND
- 245 tons from which you MAY or MAY not get a combination of loose and core samples.

Problem 1 :

Part A: How many Lots and Sublots will be involved?

1,245 tons $>$ 1,000 and $<$ 1,500. So, go to Table D.

- Using Table D, **IF** you got a combination of 3 box samples and 3 core samples from the 1,245 ton, then
 - New lot defined with 3 sublots
 - 2nd LOT = 1,245 TONS with 3 SUBLOTS
 - **TOTAL: 2 LOTS and 8 SUBLOTS**

Problem 1 :

Part A: How many Lots and Sublots will be involved?

OR

- Using Table D, IF YOU DID NOT get a combination of 3 box samples and 3 core samples, then
 - Two new sublots defined & put in previous lot
 - 1st Lot = 5 Sublots + 2 new defined sublots
 - **TOTAL: 1 LOTS and 7 SUBLOTS**

413.3(h)2.a Lots and Sublots: Table D

Re-adjustment of Lot Size & Associated Number of Sublots

Remaining Quantity* Following Last Full Lot	Action
Less than 500 tons <u>without</u> a combination of one mixture acceptance sample and one core	Quantity combined with previous lot, (n=5)
Less than 500 tons <u>with</u> a combination of one mixture acceptance sample and one core	One new subplot defined & quantity combined with previous lot, (n=6)
500 tons to less than 1000 tons <u>without</u> a combination of two mixture acceptance samples and two cores	One new subplot defined & quantity combined with previous lot, (n=6)
500 tons to less than 1000 tons <u>with</u> a combination of two mixture acceptance samples and two cores	Two new sublots defined & quantity combined with previous lot, (n=7)
1000 tons to less than 1500 tons <u>without</u> a combination of three mixture acceptance samples and three cores	Two new sublots defined & quantity combined with previous lot, (n=7)
1000 tons to less than 1500 tons <u>with</u> a combination of three mixture acceptance samples and three cores	New lot defined, (n=3)

Problem 1 : Yield determination

- **Part B:** On the same project, the length of the sublots need to be determined. The first subplot contains 500 tons. What distance will the 500 tons of HMA pave if we are placing a 12-foot wide lane at 1 ½ inches thick?

We are **assuming** a mix density of **110 lbs/inch/yd²**.

Problem 1 : Yield determination

- **Part B:** In a yield determination you either have the tons of material and want to find the area it covers **OR** you have the area it covers and want to find the amount of material (tons) needed.

You do this with the use of a **unit of material in lbs./in./yd²**.

Yield Calculations

Converting Density from “lbs./cu.-ft.” to “lbs./sq.-yd./in.”

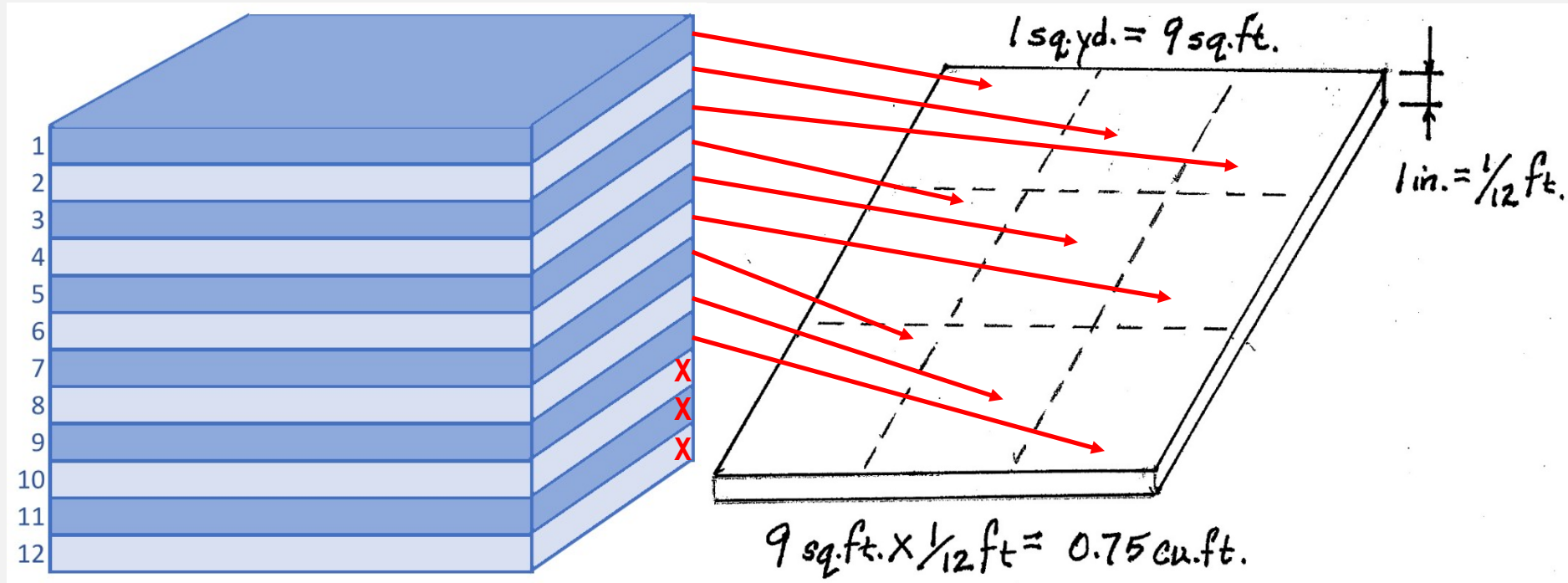

Since we only need 9 of the 12 ($9/12 = .75$ or 75%) one-inch thick “tiles” to fill one square yard,

1 pound/square-yard/inch = 75% of 1 pound/cubic-foot, therefore, multiply lbs./cu.-ft. \times 0.75 to get lbs./sq.-yd./in.

Yield Calculations

Theoretical Max. Density = 156 lbs/cu.ft. (from JMF)

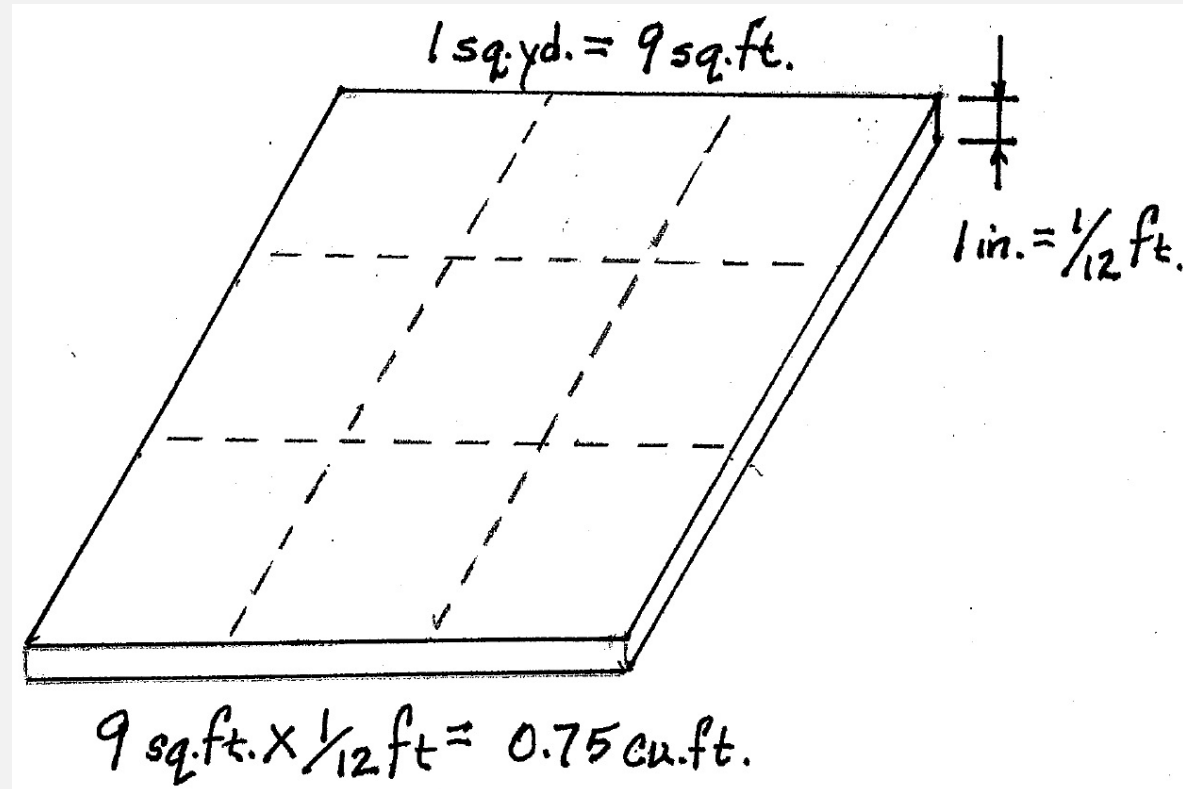

Assume: 94% average density

So, $156 \text{ lbs/cu. ft.} \times 0.75 \text{ cu. ft.} \times 0.94 = 110 \text{ lbs/sq. yd./in.}$ (unit of measure)

Problem 1: Yield Determination

Part B: What distance will the 500 tons of HMA pave?

Answer:

- $1 \frac{1}{2}$ inches x 110 lbs/inch/yd² = 165 lbs/yd²
- 500 tons x 2,000 lbs/ton = 1,000,000 lbs.
- $1,000,000 \text{ lbs.} \div 165 \text{ lbs/yd}^2 = 6,061 \text{ yd}^2$ (Area)
- Area = Length x Width or Length = Area/Width
- Width of road is 12 feet or 4 yards
- (Area) $6,061 \text{ yd}^2 \div 4 \text{ yds (width)} = 1,515 \text{ lineal yds.}$
- $1,515 \text{ yds.} \times 3 \text{ ft./yd.} = 4,545 \text{ feet.}$
- The length of the subplot is 4,545 feet.

Problem 1 : Yield determination

Part B: What distance will the 500 tons of HMA pave?

Alternative Method:

- Width of road is 12 ft.
- $6061 \text{ yd}^2 \text{ (Area)} \times 9 \text{ ft}^2/\text{yd}^2 = 54,549 \text{ ft}^2$
- $54,549 \text{ ft}^2 \div 12\text{-foot-wide lane} = 4,545 \text{ feet}$
- The length of the subplot is 4,545 feet.

Problem 1 :Sample Location

Part C: Find the location on the pavement where the first box sample would be taken. The first subplot random number is 25.

PTM 1 # 25 $X = .55$ and $Y = L 0.29$

$0.55 \times 500\text{-ton subplot} = 275\text{-ton sampling point}$

Sample will be taken from the UNIT hauling ton # 275

Answer: Random # 25: $x=0.55$ $y=L$ 0.29

**2,500 feet
or
275 ton**

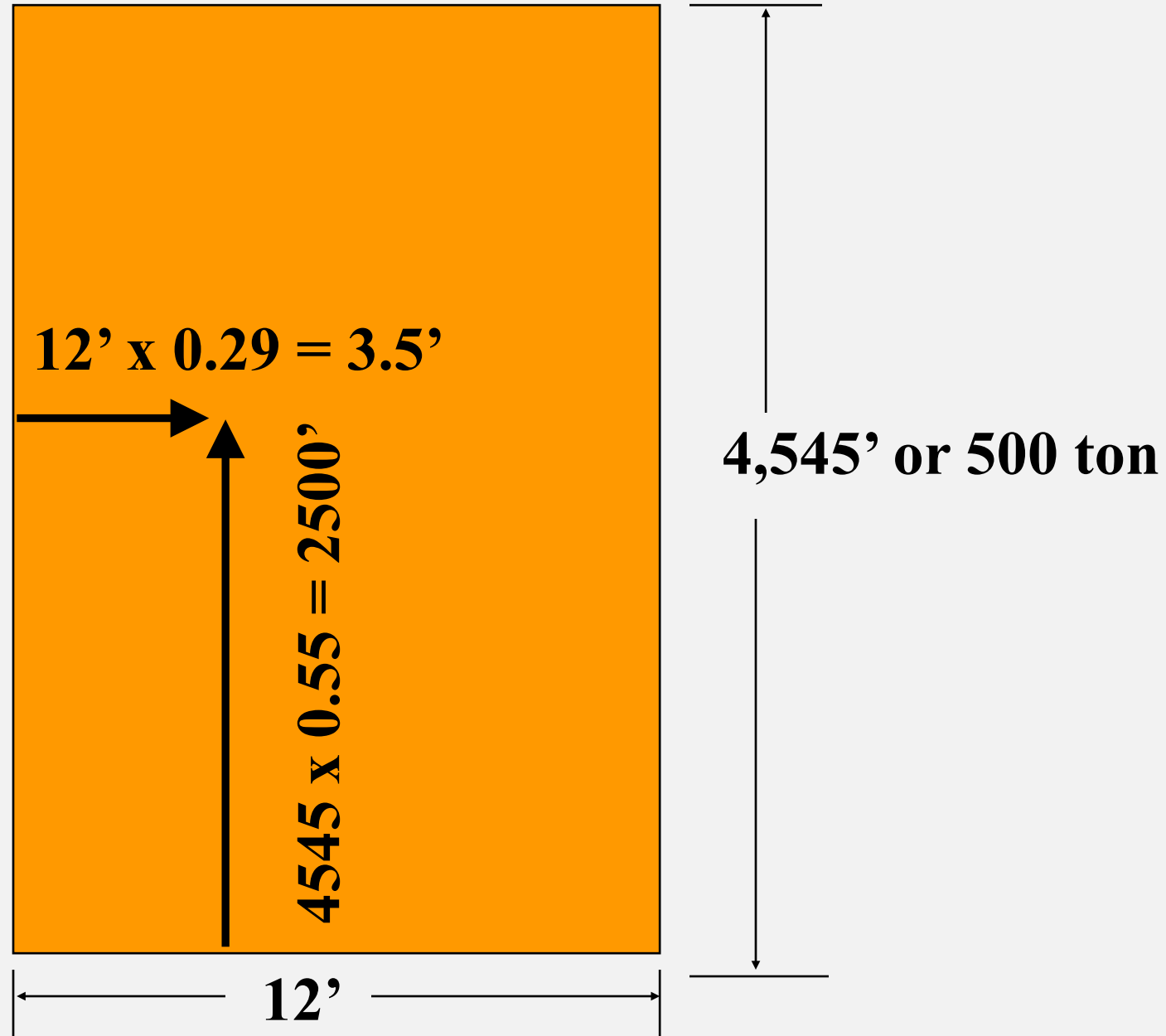

Problem 1 :Sample Location

Part D: Find the location on the pavement where you would take the third core sample. This will represent the third subplot. The first subplot PTM 1 random number is 61.

Answer: 3rd Random # is 63: $x=0.66$ $y=L0.97$

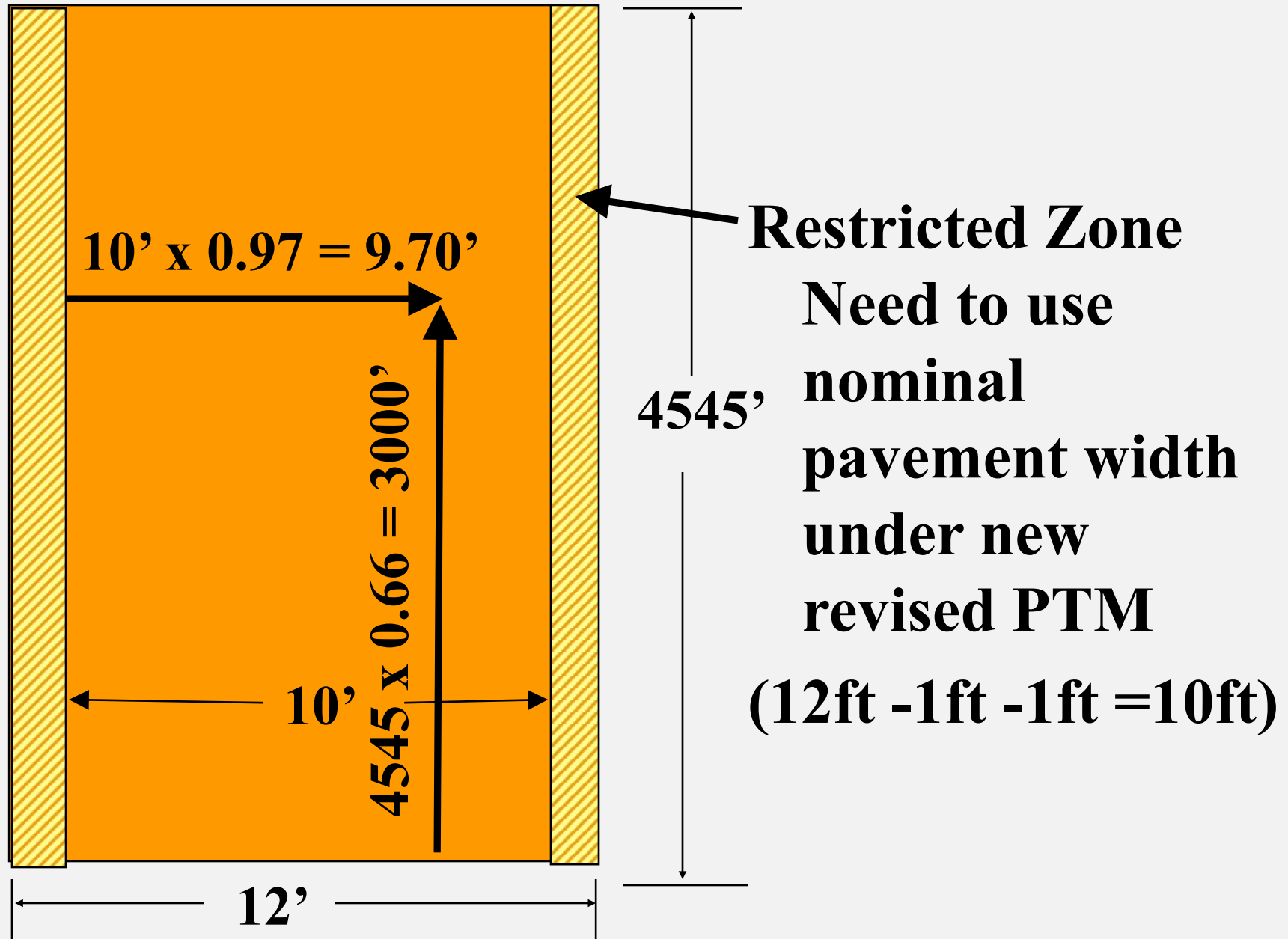

What would be the tonnage sampling point?

- First use random number in the subplot:
 $0.66 \times 500 = 330$ tons
- Then, find the tonnage in the Lot:
 $500 + 500 + 330 = 1,330$ tons

Sample from the unit hauling these tons.

Problem 2 : Yield calculation

- A Contractor is placing 18,000 yd² of Superpave Asphalt Wearing Course:
 - Binder: PG 64E-22
 - Traffic 3 to <10 million ESALS
 - NMAS: 9.5 mm mix
 - Depth & Width: 1 ½” depth for a 12-foot lane.
 - Assume **yield of 115 lb./inch/yd²** of pavement.
-

Part A: Calculate tonnage and total number of lots and sublots.

Part B: What will be the length of each subplot?

Problem 2 :

Part A: Answer

- $18,000 \text{ sq. yd.} \times 115 \text{ lbs./inch/yd}^2 \times 1 \frac{1}{2}'' = 3,105,000 \text{ lbs.}$
- $3,105,000 \text{ lbs.} \div 2000 \text{ lbs./ton} = 1,552.5 \text{ tons}$
- Total tons = 1,552.5
- Projects with total tonnage of **> 500 tons** and **<2500 tons**, tonnage is considered a lot and divided into 5 equal sublots (**rule #2**)
- 1 lot of 1,552.5 tons with 5 sublots
- $1,552.5 \text{ tons} \div 5 = \mathbf{310.5 \text{ tons per subplot}}$

Problem 2, Part B : length of each subplot

- $115 \text{ lbs./inch/yd}^2 \times 1 \frac{1}{2}'' = 172.5 \text{ lbs./yd}^2$
- $310.5 \text{ tons} \times 2000 \text{ lbs./ton} = 621,000 \text{ lbs.}$
- $621,000 \text{ lbs.} \div 172.5 \text{ lbs./yd}^2 = 3,600 \text{ yd}^2$
- $3600 \text{ yd}^2 \times 9 \text{ ft}^2/\text{yd}^2 = 32,400 \text{ ft}^2$
- $32,400 \text{ ft}^2 \div 12\text{-ft. lane} = 2,700 \text{ linear feet.}$

Alternate: $3,600 \text{ yd}^2$

- $12\text{-foot lane} = 4 \text{ yds}$
- $3,600 \text{ yd}^2 \div 4 \text{ yd.} = 900 \text{ yds}$
- $900 \text{ yds} \times 3 \text{ ft/yd.} = 2,700 \text{ linear feet.}$

Problem 3:

- A Contractor is placing approximately 6,500 tons of Superpave Asphalt Wearing Course for which **acceptance by lots** is required
 - Binder: PG 64S-22
 - Traffic Level: 3 to <10 million ESALS
 - NMAS: 9.5mm mix
 - Depth & Width: 1 ½” for a 12-foot lane
 - Duration of Paving: 4 days
- The actual daily placement is as follows:
 - 1st Day: 1,532.12
 - 2nd Day: 1,511.14
 - 3rd Day: 1,876.51
 - 4th Day: 1,532.25
- Assume **yield of 110 lb./inch/yd²** of pavement
- Calculate total number of lots and sublots, assuming you obtained the required combination of both box and core samples on the last partial lot.

How many sublots

- **6500 ÷ 500 = 13 sublots**
- **How many lots?**
- **We do not yet know**
- **Why Not?**

Problem 3:

Answer:

- Total tons = $6,452.02 \text{ tons} \div 2,500 \text{ tons/lot} = 2$ full lots (5 sublots each) with a final lot adjustment
- $2 \text{ lots} \times 2,500 \text{ tons/lot} = 5,000 \text{ tons}$
- $6,452.02 \text{ tons} - 5,000 \text{ tons} = 1,452.02 \text{ tons}$
- Using Table D to adjust final tonnage: 1,452.02 is $>1,000$ but less than 1,500
- Since you got a combination of 3 box samples and 3 core samples:
 - New lot defined with 3 sublots
- Therefore, **total of 3 completed lots and 13 sublots**

Answer: with required combination of samples

	Tons	Lot 1	Lot 2	Lot 3
Day 1	1,532.12	1,532.12		
Day 2	1,511.14	967.88	543.26	
Day 3	1,876.51		1,876.51	
Day 4	1,532.25		80.23	1,452.02
Total Tons	6,452.02	2,500	2,500	1,452.02
Sublots		5	5	3

Problem 4: Paving Delay

- A Contractor is placing approximately 6,500 tons of Superpave Asphalt Wearing Course for which **acceptance by lots** is required
 - Binder: PG 64S-22
 - Traffic Level: 3 to <10 million ESALS
 - NMAS: 9.5mm mix
 - Depth & Width: 1 ½” for a 12-foot lane
 - Duration of Paving: 4 days
- The actual daily placement is as follows:
 - 1st Day: 1,532.12
 - 2nd Day: 1,511.14
 - 3rd Day: 1,876.51
 - **Delayed 7 days**
 - 10th Day: 1,532.25
- Assume **yield of 110 lb./inch/yd²** of pavement

Problem 4: Paving Delay

- Calculate total number of lots and sublots.
Assume a full combination of samples obtained on last lot at end of 3rd Day.
Assume *not* a full combination of samples obtained on the last lot of the 10th day.

Answer:

3 Lots and 13 Sublots

Answer:

	Tons	Lot 1	Lot 2	Lot 3
Day 1	1,532.12	1,532.12		
Day 2	1,511.14	967.88	543.26	
Day 3	1,876.51		1,876.51	
Total tons	4,919.77	2500	2,419.77	
Sublots		5	5*	
5 days or more delay				
Day 10	1,532.12			1,532.12
Sublots				3**

***with combination of required samples**

****without combination of required samples**

Asphalt Construction Program

Certified Asphalt Field Technician

Pennsylvania Test Methods (PTMs) for Field Technicians



What you need to know...

Which Pennsylvania Test Methods apply to the field?

- The P.T.M.'s in the asphalt paving operations
- The purpose of each of these important test methods

<u>PENNSYLVANIA TEST METHODS (PTM'S)</u>		
<u>Table of Contents – May 2018</u>		
<u>TEST TITLE</u>	<u>PTM NO.</u>	<u>REVISION DATE</u>
Probability Sampling	1	October 2013
Treatment of Extreme Values	4	October 2013
Evaluating Testing Repeatability	5	October 2013
Determination of Percent Within Limits (PWL) for Construction Aggregate	6	October 2013
Amount of Material Finer than 75 µm No. 200 Sieve, Aggregate	100	October 2013
The Moisture-Density Relations of Soils (Using 5.5-lb Rammer and a 12" men Drop)	106	October 2017
Determining Slake Durability of Rocks by the Jar Slake Test	122	May 2018
Sample Preparation of Fine Material for Mechanically Stabilized Earth (MSE) Retaining Walls	127	October 2013
Evaluation of Potential Expansion of Test Slabs	130	January 2016
Determination of Coefficient of Uniformity	149	October 2013
Field Sampling of Coated Films for Laboratory Analysis of Toxic Metal Content	200	October 2013
Weight Per Liter of Paint	201	October 2013
Patch Test for Assessing Coating Compatibility	207	October 2013
Sampling and Testing Treated Wood Products	210	October 2013
Cloud Point of Diesel Fuel	211	October 2013
Determining Cell Seam Peel Strength and Spacing and Cell Depth of Geocell	301	May 2018
Sponge Elastomers Low Temperature Brittleness	305	October 2013

1

P.T.M.'s for Field Technicians

- **PTM 001: Probability Sampling**
- **PTM 402: Determining In-Place Density Using Nuclear Gauges**
- **PTM 403: Determining In-Place Density Using Electrical Impedance Measurement Methods**
- **PTM 428: Measuring Pavement Profile Using a Light-Weight Profiler**
- **PTM 729: Sampling Roadway Asphalt Concrete**
- **PTM 737: Measuring Thickness of Asphalt Concrete Courses**

P.T.M.'s for Field Technicians

- **PTM 746:** Sampling Asphalt Paving Mixtures
 - **PTM 747:** Determination of Distributor Application Rate in the Field
 - **PTM 751:** Measuring Surface Macrotexture Depth Using a Volumetric Technique & Determining Pattern Segregation
-
-

Laboratory Tests (PTMs for Plant Technicians):

- **PTM 715/716:** Determination of Bulk Specific Gravity of Compacted Asphalt Mixtures
- **AASHTO T 209:** Maximum Specific Gravity of Asphalt Mixtures (Vacuum Method)

PTM 1

Probability Sampling

PTM #1: Probability Sampling

- Selecting samples using probability sampling techniques
- Selecting all Department samples in an unbiased manner, based entirely on chance
- Samples divided into Lots and Sublots

Random Number Table

	X		Y
1.	0.29	R	0.66
2.	0.74	R	0.49
3.	0.89	L	0.79
4.	0.60	R	0.39
5.	0.88	R	0.31
	.		.
	.		.

Procedure:

- Determine lot size and number of sublots per lot from the specifications.
- Select a set of consecutive numbers from random number table--one for each subplot.
- For roadway sampling, values in X and Y columns give coordinates of sample.

Random Number Table

$Y \text{ times } W \text{ (width of paving)} = 0.79 \times W$

	X		Y
1.	0.29	R	0.66
2.	0.74	R	0.49
3.	0.89	L	0.79
4.	0.60	R	0.39
5.	0.88	R	0.31

*R or L indicates measurement from right or left edge of paved lane

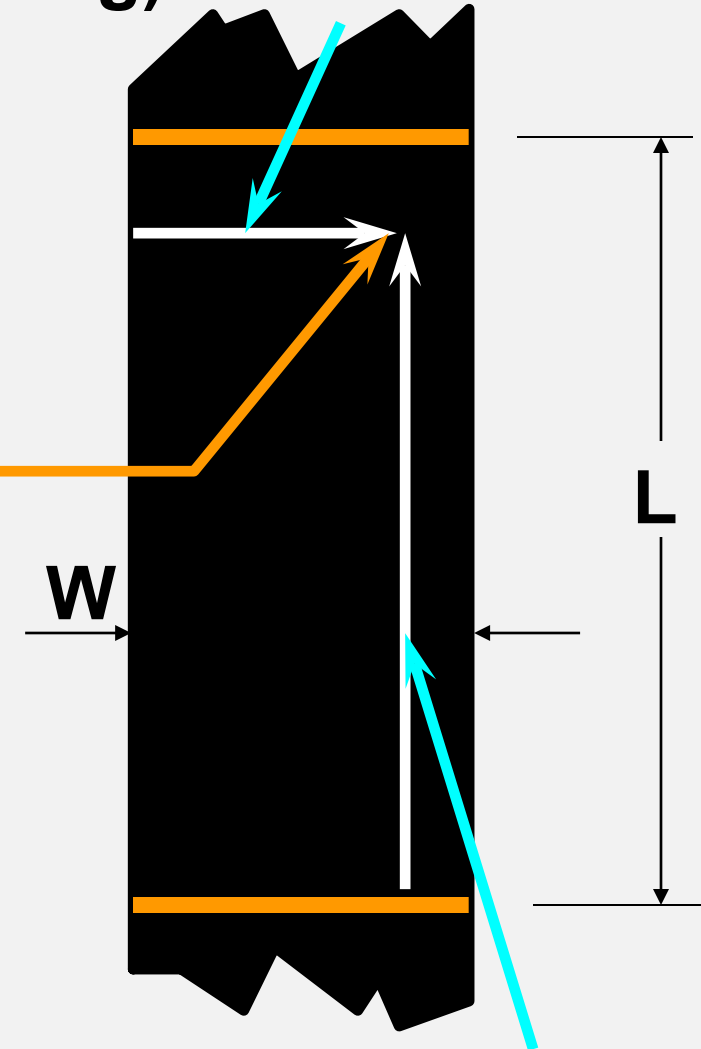

$X \text{ times } L \text{ (Length of subplot)} = 0.89 \times L$

Determining Sample Location



Length or “X” value

Offset or “Y” value



Example: RPS Lot (Box Sample)

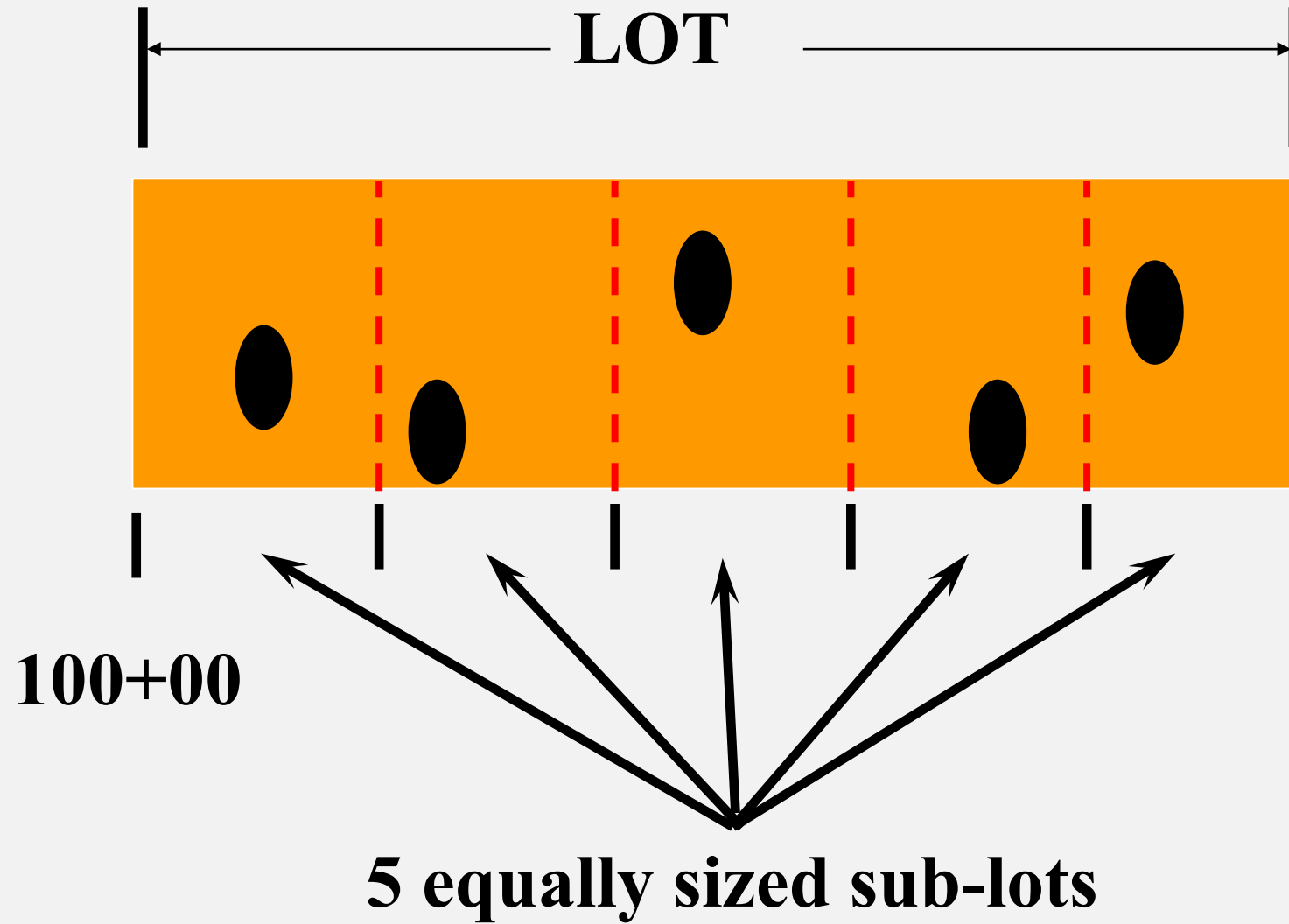

PTM 402

**Determine In-Place Density by Use of
Nuclear Gauges**

and

PTM 403

**Determine In-Place Density Using
Electrical Impedance Measurement
Methods**

PTM #402: In-Place Density by Use of Nuclear Gauges

- **Nuclear Density Gauge**
- **Standardization**
- **Location**

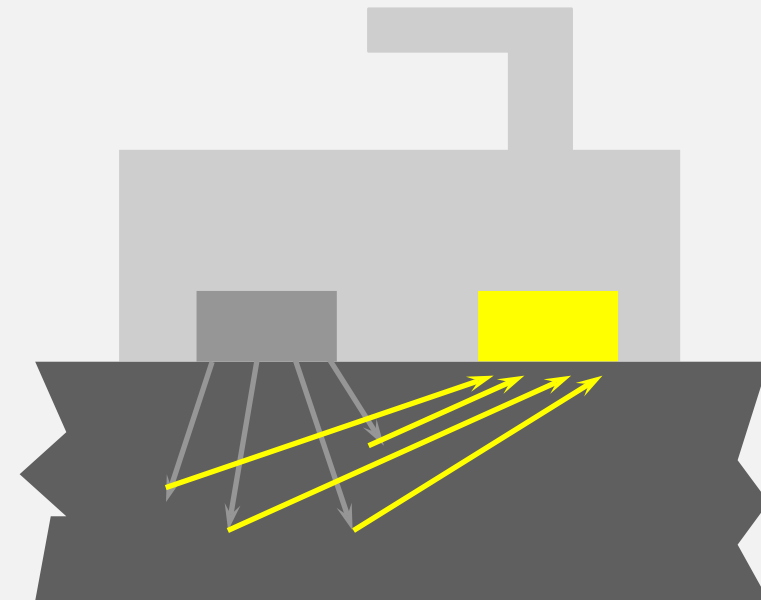
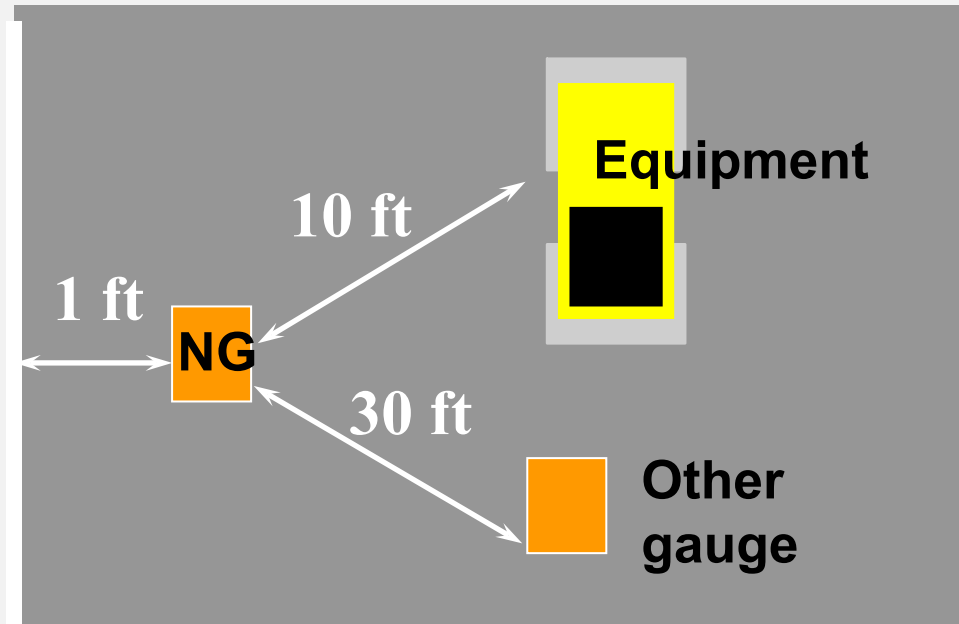

PTM #402: In-Place Density by use of a Nuclear Gauge

- Test Site Preparation
- Standard count *daily*



TR-4276B (3-15)

pennsylvania
DEPARTMENT OF TRANSPORTATION
www.dot.state.pa.us

OPTIMUM-ROLLING PATTERN FOR BITUMINOUS DENSITY ACCEPTANCE BY NUCLEAR METHOD
(REFERENCE: PTM NO. 402)

ECMS # _____ S.R. _____ Sec. _____ County _____ District _____ Date _____
Material Type _____ JMF # _____ Theoretical Max Density _____ pcf Thickness _____

NUCLEAR GAUGE STANDARDIZATION PROCEDURE

DENSITY Standard Counts	MOISTURE Standard Counts	OPERATING LIMITS		Tested By _____ Gauge Manufacturer _____ Gauge Model No. _____ Calibration Date _____ Remarks: _____
		Density	Moisture	
		to _____	to _____	

ESTABLISHMENT OF OPTIMUM-ROLLING PATTERN

Roller No. 1				Roller No. 2				Roller No. 3			
Type	Density, pcf	% Density	Temp, °F	Type	Density, pcf	% Density	Temp, °F	Type	Density, pcf	% Density	Temp, °F
1.				1.				1.			
2.				2.				2.			
3.				3.				3.			
4.				4.				4.			
5.				5.				5.			
6.				6.				6.			
7.				7.				7.			
8.				8.				8.			
9.				9.				9.			
10.				10.				10.			

Optimum No. Passes _____ Minimum No. Passes _____ Station No. _____
Surface Temp Range _____ Sub. Temp Range _____

Form TR-4276B

OPTIMUM-ROLLING PATTERN GROWTH CURVE

SUMMARY OF OPTIMUM-ROLLING PATTERN DENSITY

Location	Offset	Density
1.		
2.		
3.		
4.		
5.		
6.		
7.		
8.		
9.		
10.		

TARGET DENSITY _____

Each roller should make at least three (3) passes, and compaction with each roller shall continue until the increase of three (3) successive readings is ≤ 3.0 pcf. The optimum number of passes will be either the 2nd or 3rd pass from the three (3) successive readings with the greatest increase in compaction. If a decompaction reading is obtained, the previous pass will be the optimum number of passes for that roller. Then, proceed to the next roller or temperature range.

- Operator must be licensed & gauge must be type approved by PennDOT

PTM #402: In-Place Density by Use of Nuclear Gauges

(Form CS 4276B)

Use this Form for
Establishment of
Optimum Rolling Pattern

TR-4276B (3-15)



pennsylvania
DEPARTMENT OF TRANSPORTATION
www.dot.state.pa.us

OPTIMUM-ROLLING PATTERN FOR BITUMINOUS DENSITY ACCEPTANCE BY NUCLEAR METHOD
(REFERENCE: PTM NO. 402)

ECMS # _____ S.R. _____ Sec. _____ County _____ District _____ Date _____
 Material Type _____ JMF # _____ Theoretical Max Density _____ pcf Thickness _____

NUCLEAR GAUGE STANDARDIZATION PROCEDURE

DENSITY Standard Counts	MOISTURE Standard Counts	OPERATING LIMITS		Tested By _____ Gauge Manufacturer _____ Gauge Model No. _____ Calibration Date _____ Remarks: _____
		Density	Moisture	
		to	to	

ESTABLISHMENT OF OPTIMUM-ROLLING PATTERN

Roller No. 1				Roller No. 2				Roller No. 3			
Type	Density, pcf	% Density	Temp. °F	Type	Density, pcf	% Density	Temp. °F	Type	Density, pcf	% Density	Temp. °F
1.	_____	_____	_____	1.	_____	_____	_____	1.	_____	_____	_____
2.	_____	_____	_____	2.	_____	_____	_____	2.	_____	_____	_____
3.	_____	_____	_____	3.	_____	_____	_____	3.	_____	_____	_____
4.	_____	_____	_____	4.	_____	_____	_____	4.	_____	_____	_____
5.	_____	_____	_____	5.	_____	_____	_____	5.	_____	_____	_____
6.	_____	_____	_____	6.	_____	_____	_____	6.	_____	_____	_____
7.	_____	_____	_____	7.	_____	_____	_____	7.	_____	_____	_____
8.	_____	_____	_____	8.	_____	_____	_____	8.	_____	_____	_____
9.	_____	_____	_____	9.	_____	_____	_____	9.	_____	_____	_____
10.	_____	_____	_____	10.	_____	_____	_____	10.	_____	_____	_____
Optimum No. Passes _____			Optimum No. Passes _____			Optimum No. Passes _____					
Surface Temp Range _____			Surface Temp Range _____			Surface Temp Range _____					

OPTIMUM-ROLLING PATTERN GROWTH CURVE

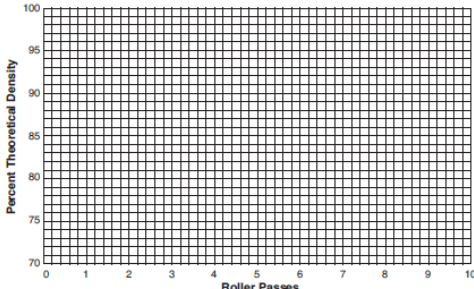

Percent Theoretical Density

Roller Passes

SUMMARY OF OPTIMUM-ROLLING PATTERN DENSITY

Location	Offset	Density
1.	_____	_____
2.	_____	_____
3.	_____	_____
4.	_____	_____
5.	_____	_____
6.	_____	_____
7.	_____	_____
8.	_____	_____
9.	_____	_____
10.	_____	_____
TARGET DENSITY		_____

Each roller should make at least three (3) passes, and compaction with each roller shall continue until the increase of three (3) successive readings is ≤ 3.0 pcf. The optimum number of passes will be either the 2nd or 3rd pass from the three (3) successive readings with the greatest increase in compaction. If a decompaction reading is obtained, the previous pass will be the optimum number of passes for that roller. Then, proceed to the next roller or temperature range.

Establish Rolling Pattern

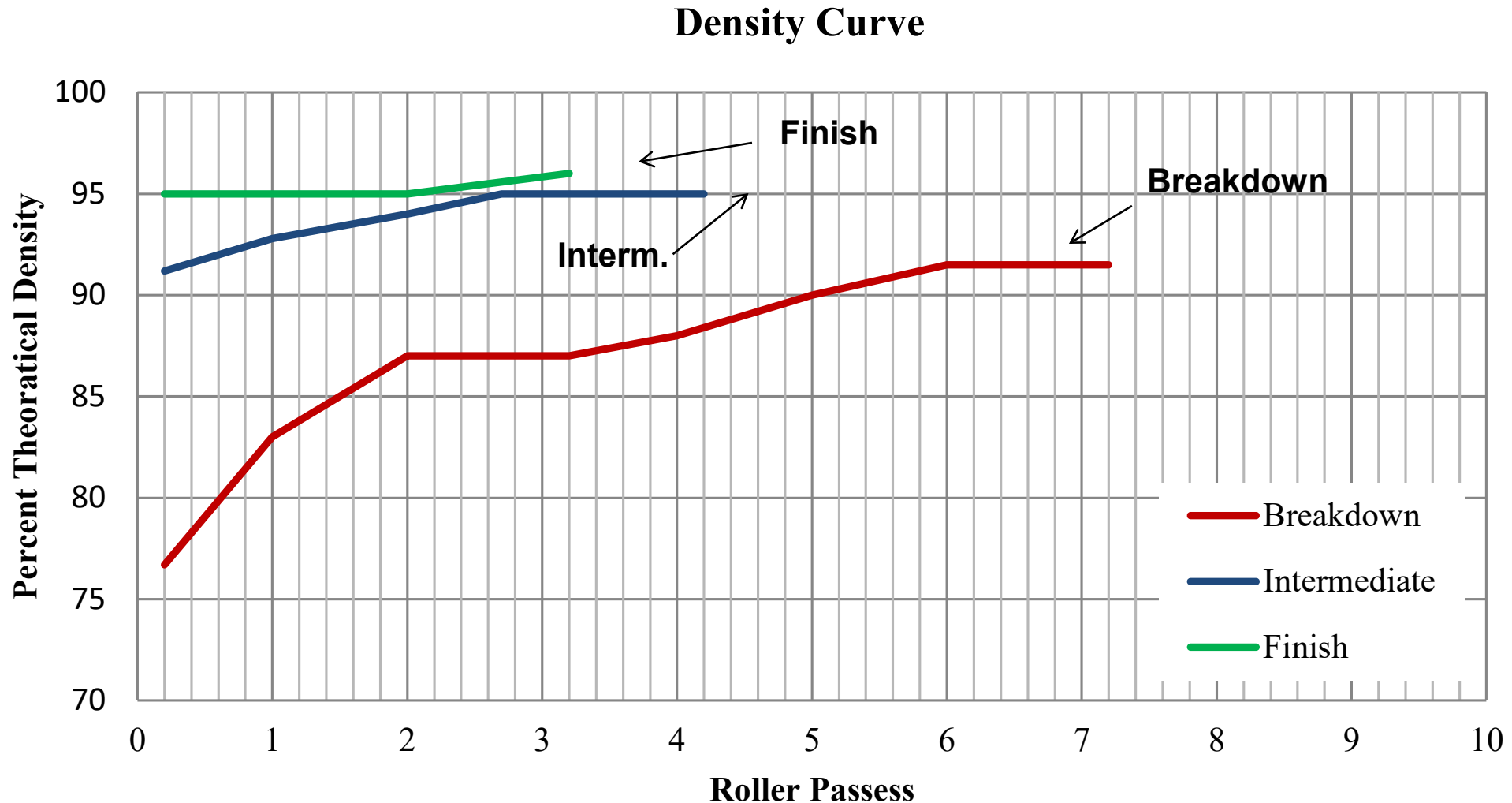

PTM #402:

In-Place Density by Use of Nuclear Gauges

(Form CS 4276A)

Use this Form to Report on
Compaction Density by
Nuclear Method

Not Required for Optimum
Roller Pattern Acceptance

TR-4276A (3-15)

pennsylvania
DEPARTMENT OF TRANSPORTATION
www.dot.state.pa.us

**REPORT ON COMPACTION DENSITY
BY NUCLEAR METHOD**
(Reference: PTM No. 402)

Fill Out Completely. Original to be retained with project records. Remit copy to District Office

ECMS # _____ S.R. _____ Sec. _____ County _____ District _____ Date _____

TYPE OF CONSTRUCTION: Embankment Subgrade Pipe Backfill Other _____
(check one type only)

1. Test No.					
2. Time of Test					
3. Type of Material					
4. Source of Material					
5. Specific Gravity of Material (SG)					
6. Station					
7. Offset					
8. Subgrade Elevat					
9. Test Location, n					
10. Test Depth, in.					
11. Source Position					
12. Density (Proctor), pcf					
13. Optimum Moisture, %					
14. % Passing 3/8" Sieve					
15. % Passing No. 200 Sieve					
16. Minimum Density Req.					
17. Minimum Moisture of Test					
18. Density (DD)					
19. Density (WD)					
20. Moisture (M)					
21. % Moisture (M%)					
22. Density Count (Shift + Counts)					
23. Moisture Count (Shift + Counts)					
24. Zero Air Voids Formula Check (Y/N)					
25. (P)ASS or (F)AIL					

DENSITY Standard Counts	MOISTURE Standard Counts	OPERATING LIMITS Density Moisture		Tested By _____ Gauge Manufacturer _____ Gauge Model No. _____ Calibration Date _____ Remarks:
		to	to	

Zero Air Voids Formula

$$\frac{62.4}{DD} - \frac{1}{SG} \geq M\%$$

PTM #403: In-Place Density Using Electrical Impedance Measurement

- **Rapid non-destructive technique**
- **PennDOT approved instrument**



- **Calibration**
- **Test Site Preparation**



PTM #403: In-Place Density Using Electrical Impedance Measurement

(Form CS 4276C)

Use this form to record data

TR-4276C (3-15)

pennsylvania
DEPARTMENT OF TRANSPORTATION
www.dot.state.pa.us

OPTIMUM-ROLLING PATTERN FOR BITUMINOUS DENSITY ACCEPTANCE BY ELECTRICAL IMPEDANCE MEASUREMENT METHOD
(Reference: PTM No. 403)

ECMS # _____ S.R. _____ Sec. _____ County _____ District _____ Date _____

Material Type _____ JMF # _____ Theoretical Max Density _____ pcf Thickness _____

ELECTRICAL IMPEDANCE GAUGE CALIBRATION PROCEDURE

Gauge Operator _____ Manufacturer _____ Model No. _____

Screed Density = Estimated Screed Density (As Decimal) _____ x Theoretical Max Density _____ = _____ pcf

Reading 1	Reading 2	Reading 3	Reading 4	Reading 5	Total	Average	Screed Density	Offset Value
_____	_____	_____	_____	_____	_____	_____	_____	_____

Screed _____ + _____ + _____ + _____ + _____ = _____ ÷ 5 = _____ - _____ = _____

ESTABLISHMENT OF OPTIMUM-ROLLING PATTERN

Roller No. 1			Roller No. 2			Roller No. 3					
Type	Density, pcf	% Density	Temp, °F	Type	Density, pcf	% Density	Temp, °F	Type	Density, pcf	% Density	Temp, °F
1.	_____	_____	_____	1.	_____	_____	_____	1.	_____	_____	_____
2.	_____	_____	_____	2.	_____	_____	_____	2.	_____	_____	_____
3.	_____	_____	_____	3.	_____	_____	_____	3.	_____	_____	_____
4.	_____	_____	_____	4.	_____	_____	_____	4.	_____	_____	_____
5.	_____	_____	_____	5.	_____	_____	_____	5.	_____	_____	_____
6.	_____	_____	_____	6.	_____	_____	_____	6.	_____	_____	_____
7.	_____	_____	_____	7.	_____	_____	_____	7.	_____	_____	_____
8.	_____	_____	_____	8.	_____	_____	_____	8.	_____	_____	_____
9.	_____	_____	_____	9.	_____	_____	_____	9.	_____	_____	_____
10.	_____	_____	_____	10.	_____	_____	_____	10.	_____	_____	_____

Optimum No. Passes _____ Surface Temp Range _____

Optimum No. Passes _____ Surface Temp Range _____

Optimum No. Passes _____ Surface Temp Range _____

OPTIMUM-ROLLING PATTERN GROWTH CURVE

SUMMARY OF OPTIMUM-ROLLING PATTERN DENSITY

Location	Offset	Density
1.	_____	_____
2.	_____	_____
3.	_____	_____
4.	_____	_____
5.	_____	_____
6.	_____	_____
7.	_____	_____
8.	_____	_____
9.	_____	_____
10.	_____	_____

TARGET DENSITY _____

Each roller should make at least three (3) passes, and compaction with each roller shall continue until the increase of three (3) successive readings is ≤ 3.0 pcf. The optimum number of passes will be either the 2nd or 3rd pass from the three (3) successive readings with the greatest increase in compaction. If a decompaction reading is obtained, the previous pass will be the optimum number of passes for that roller. Then, proceed to the next roller or temperature range.

Optimum Roller Pattern

- The intent is to achieve the maximum density possible under existing conditions, material characteristics, ambient temperature and roller capabilities.
- **3 successive passes that do NOT increase density by 3 lbs./cu. ft.** indicate further rolling is ineffective at that temperature with that machine

Optimum Roller Pattern

- Electrical Impedance or Nuclear gauge must be calibrated DAILY.
- Readings must be taken from *same location after each pass* of the roller.
- Each roller must make AT LEAST 3 passes.
- Record results of each pass.

Optimum Roller Pattern

- If the density increase for 3 successive passes is less than 3 lbs. /cu. ft., the optimum pass will be the one with the greatest increase of the 3 passes.
- No readings required until after 2nd pass of pneumatic tire roller.
- Record results on proper form, document ten random readings and average density.
- Should be performed **DAILY**, and may be required more than once per day.

PTM 729

Sampling Roadway Asphalt Concrete

PTM 729

12 Pages

- **Contains information on equipment, selection of sample locations, (both roadway and longitudinal joint), procedures, packaging and identification, and examples**

PTM #729: Sampling Roadway Asphalt Concrete

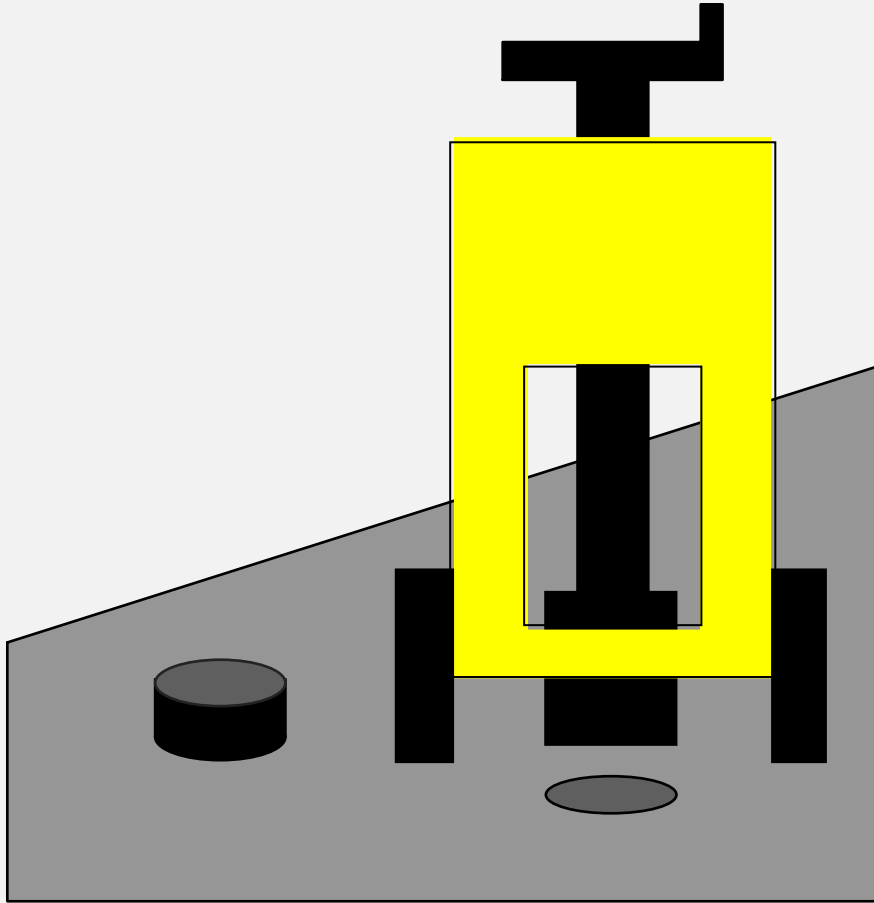

Coring

PTM #729: Sampling Roadway Asphalt Concrete

- Testable width will equal the nominal paving width less one foot from each supported edge and each unsupported edge
- Example: 12-foot paving lane:
12 ft. -1 ft. -1 ft. = 10 ft.

10 ft. is the sampling width to be used with random number table.

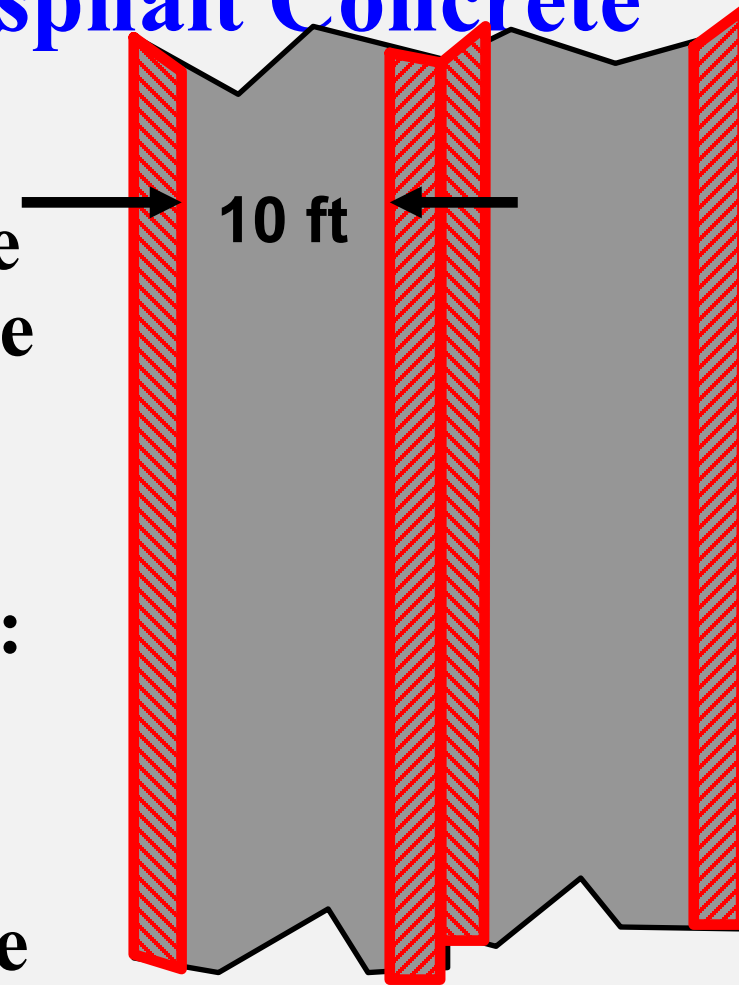

PTM #729: Sampling Roadway Asphalt Concrete

- Defines non-testable areas as one foot from the edge of obstructions such as manholes, inlets, and utility valve covers.
- If sample location falls within, adjust location longitudinally in direction of paving to just outside the non-testable area.

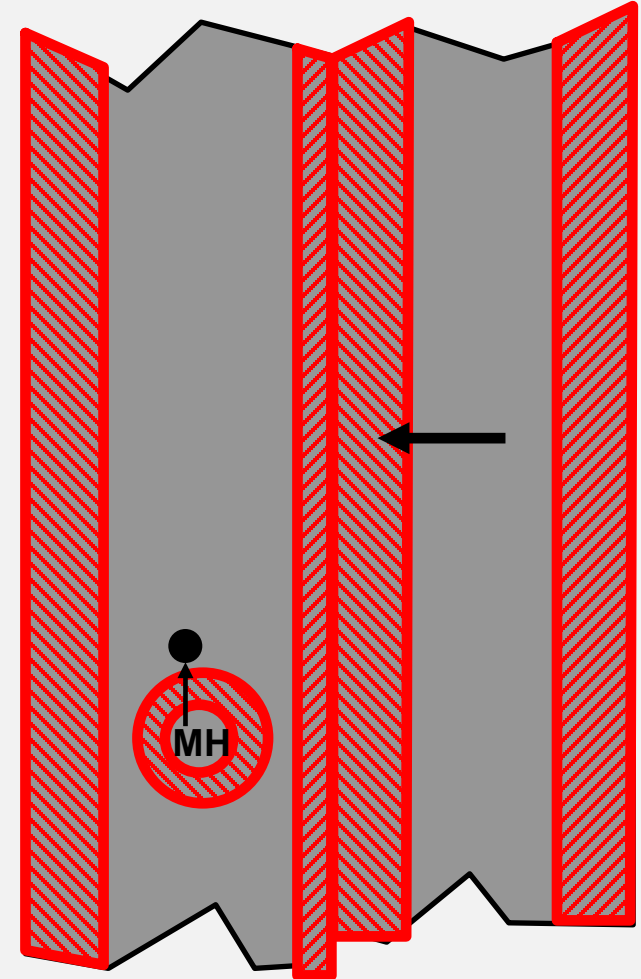

PTM #729: Sampling Roadway Asphalt Concrete

- **Equipment:**
 - Powered Core drill, water cooled, equipped to core samples
 - Diamond drill bits of 6” size
 - **Suitably sized boxes**
 - A rigid plate or suitable container to hold sample without distortion after removal (Concrete cylinder molds)
 - Masking tape
 - Marking pencil **or lumber crayon**

PTM 729: Sampling Roadway Asphalt Concrete³⁶

- **Incidental materials and equipment**
- **Hand-held core sample extraction tool capable of grasping and removing the core sample without damage to the core sample**

PTM #729:

Sampling Roadway Asphalt Concrete

- Random sampling using PTM #1 with one sample from each subplot
- Density samples to be cross referenced to corresponding loose mix acceptance (box) samples on Form TR-477.
- Place increment bar code sticker from form TR-447 on outside container.
- Secure cored samples with masking tape.
- Store in safe, cool place and transport in timely manner.

PTM #729: Sampling Roadway Asphalt Concrete

- **PTM Appendix provides examples for locating samples**
 - **Example 1:** Location adjustment for edges
 - **Example 2:** Location adjustment for obstructions

PTM #729: Sampling Roadway Asphalt Concrete

Selection of Longitudinal Joint Incentive/Disincentive Samples

- Samples by random sampling using PTM #1
Random Numbers, X value only
- Lots determined as paving progresses
- Full lot = 12,500 linear feet
- 5 sublots of 2,500 feet per lot
- One sample from each subplot.

PTM #729

Locating Longitudinal Joint Cores

	X	Y	Linear Feet by Sublot	Total Lot LF
47	0.93	N/A	0.93 x 2,500 ft = 2325	2,325
48	0.43	N/A	0.43 x 2,500 ft = 1075	3,575
49	0.99	N/A	0.99 x 2,500 ft = 2475	7,475
50	0.61	N/A	0.61 x 2,500 ft = 1525	9,025
51	0.87	N/A	0.87 x 2,500 ft = 2175	12,175

PTM #729

Locating Longitudinal Joint Cores

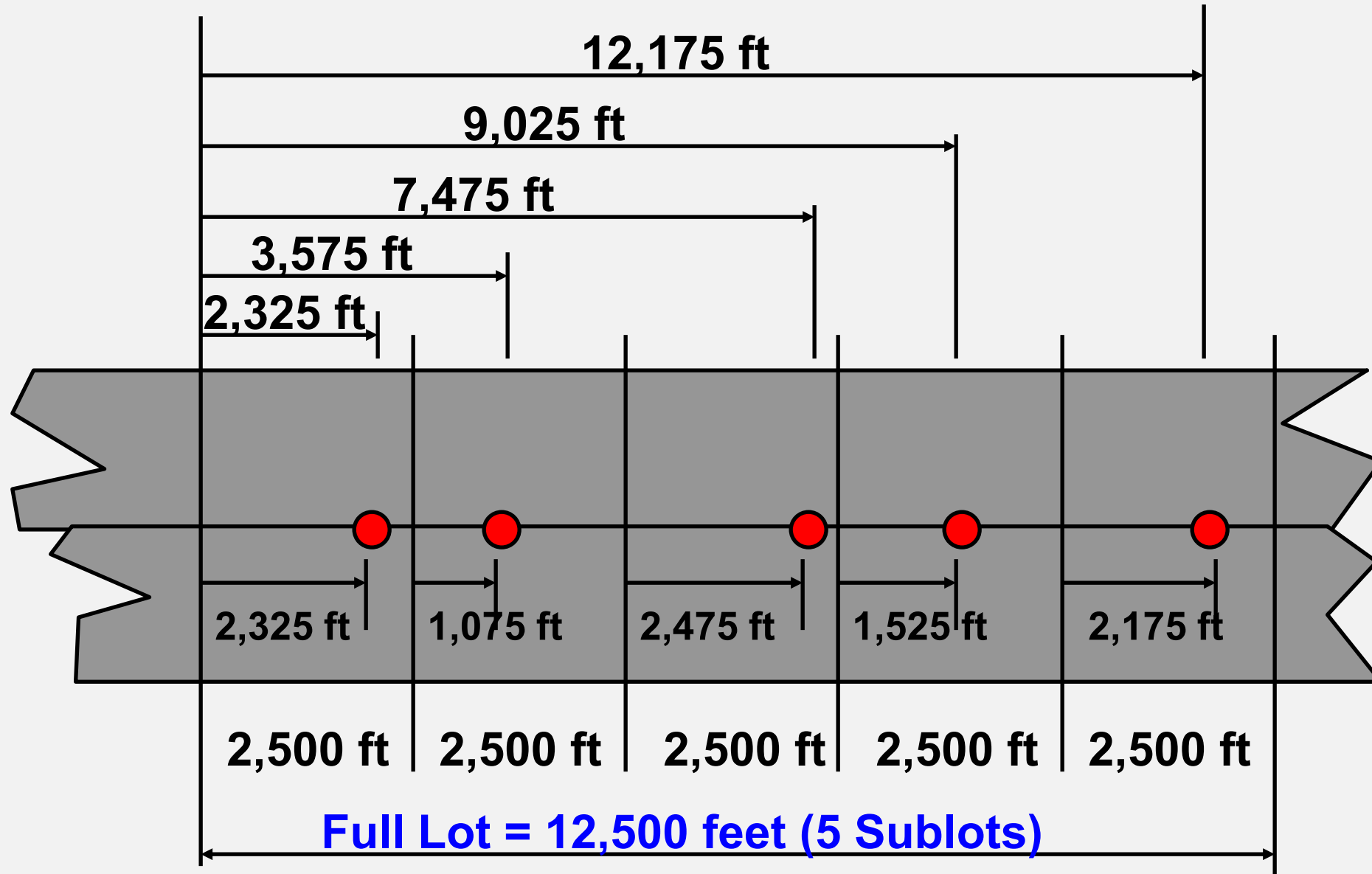

PTM #729

Locating Longitudinal Joint Cores

Example from PTM Appendix – Example No. 3

Sampling Sequence for LOT (12,500 linear feet)			
Sublot 1	2,325	=	Station 23+25
Sublot 2	2,500 + 1,075	=	Station 35+75
Sublot 3	5,000 + 2,475	=	Station 74+75
Sublot 4	7,500 + 1,525	=	Station 90+25
Sublot 5	10,000 + 2,175	=	Station 121+75

PTM #729

Location of Longitudinal Joint Cores

- Length of final lot is adjusted to ensure final lot has between 3 to 7 sublots (See Example #3 in PTM Appendix)
- For final subplot, use a length of 2500 feet and multiply by the x value of the random number
- If sample falls beyond actual length of joint, subplot not counted and no sample taken
- If sample falls within actual length of joint, sample taken and subplot added to final lot.

PTM #729

Location of Longitudinal Joint Cores

- **Location of cores on joint**
 - With vertical joints, cores centered on surface joint line
 - Center of core to be within 1 inch of joint line
 - With notch wedge joints, cores centered 6 inches or half the wedge width of the joint taper away from the joint line in direction of wedge
 - If G_{mm} of each lane differs by more than 0.050, ensure half of core is from each lane
 - If not, adjust lateral location for replacement core within 12 inches longitudinally

PTM #729

Location of Longitudinal Joint Cores

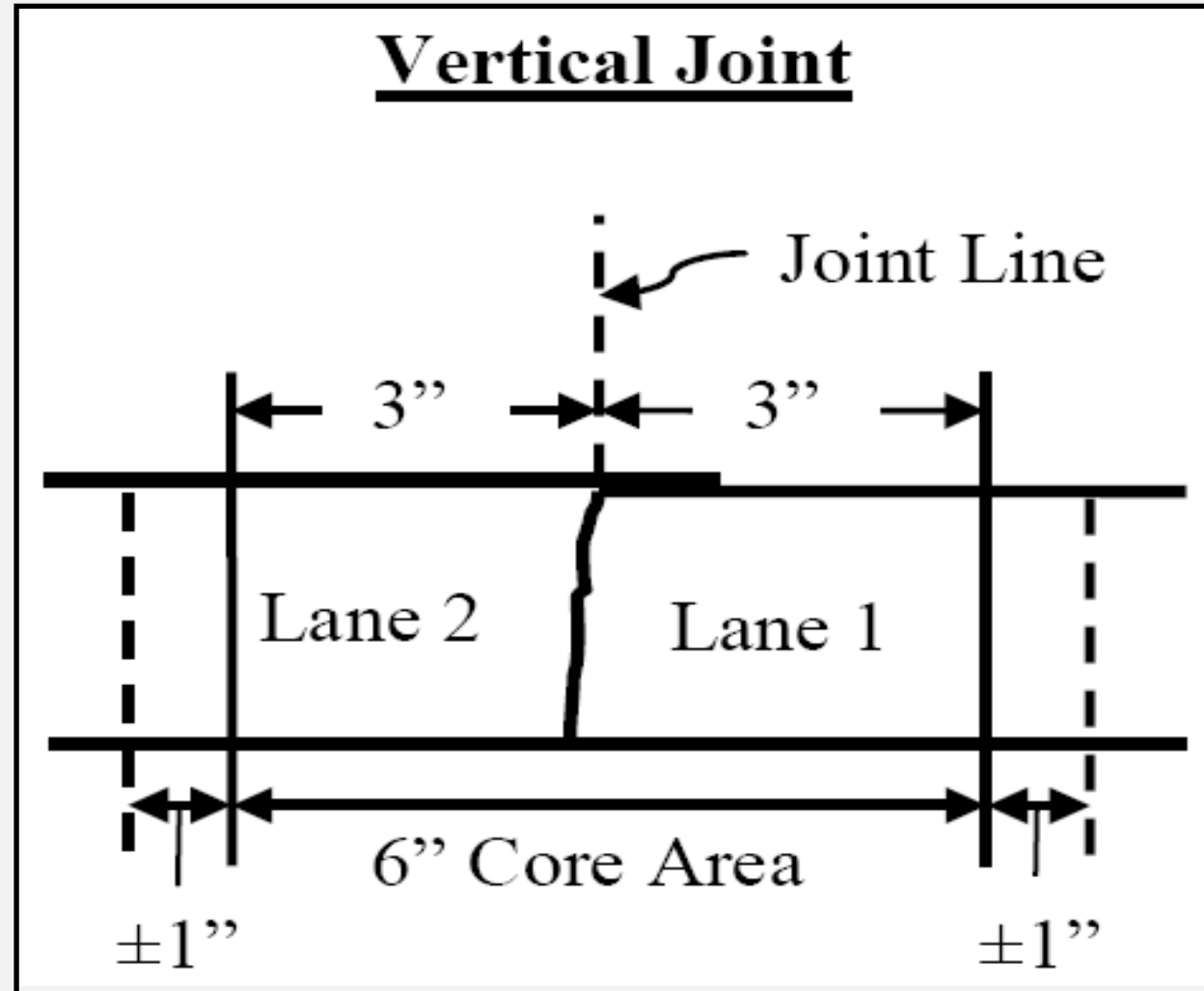

PTM #729

Location of Longitudinal Joint Cores

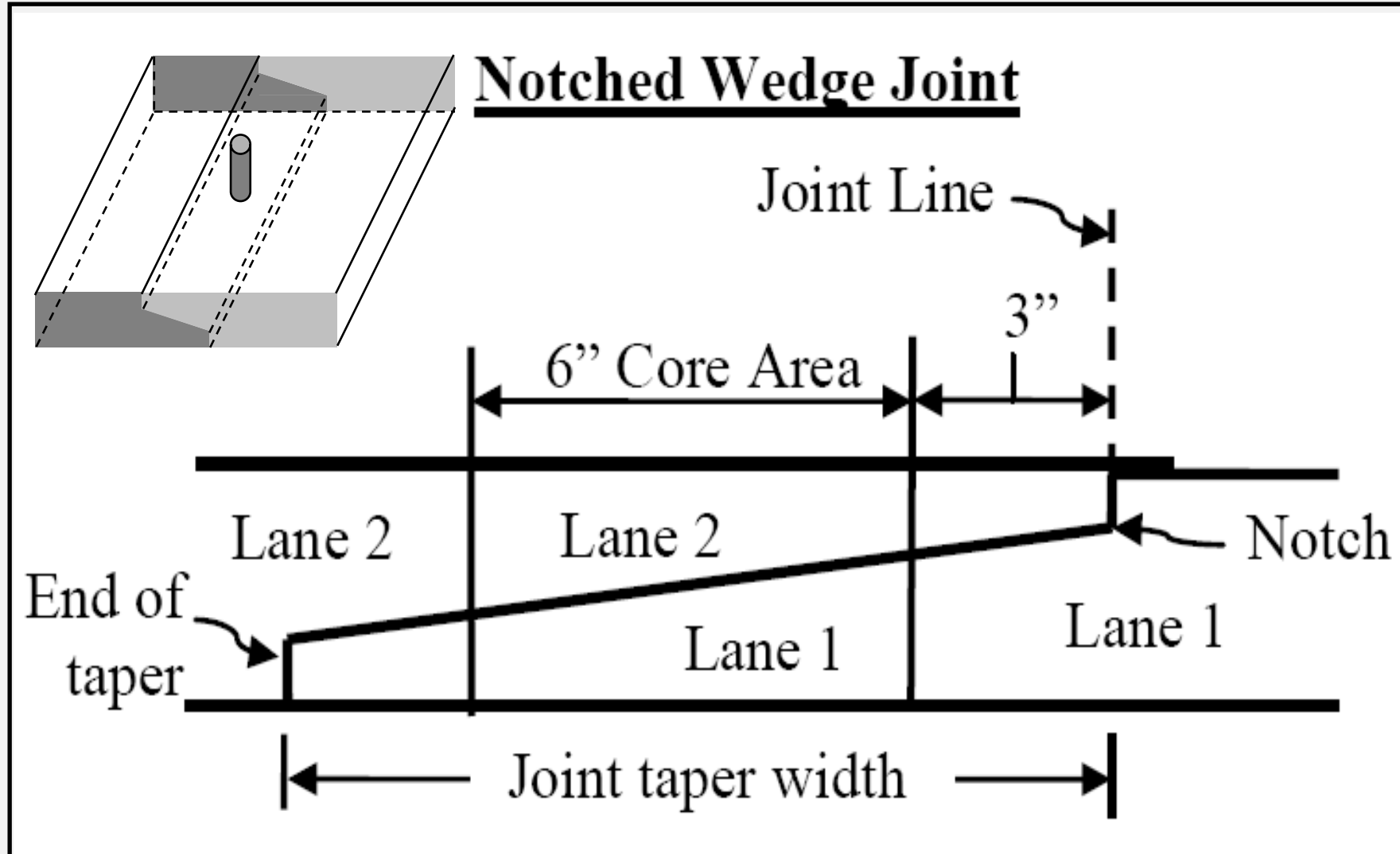

Using TR-447 for Longitudinal Joint Cores

- Cores taken from same lot with same JMF packaged and recorded on the same TR-447
- Cores from Different JMF's on separate TR-447
- Cores from Paving Break > 5 days on Separate TR-447

PTM #737:

Measuring Thickness Of Asphalt Concrete Courses

- Section 413.3(m) requires inspector to measure depth of cores
- Minimum of 4 measurements 90° apart and averaged.
- Depth of course recorded to nearest 1/8 inch.

Note: Department representative and contractor CFT should be present when cores are measured.

If the bottom is irregular, more than 4 measurements may be averaged.

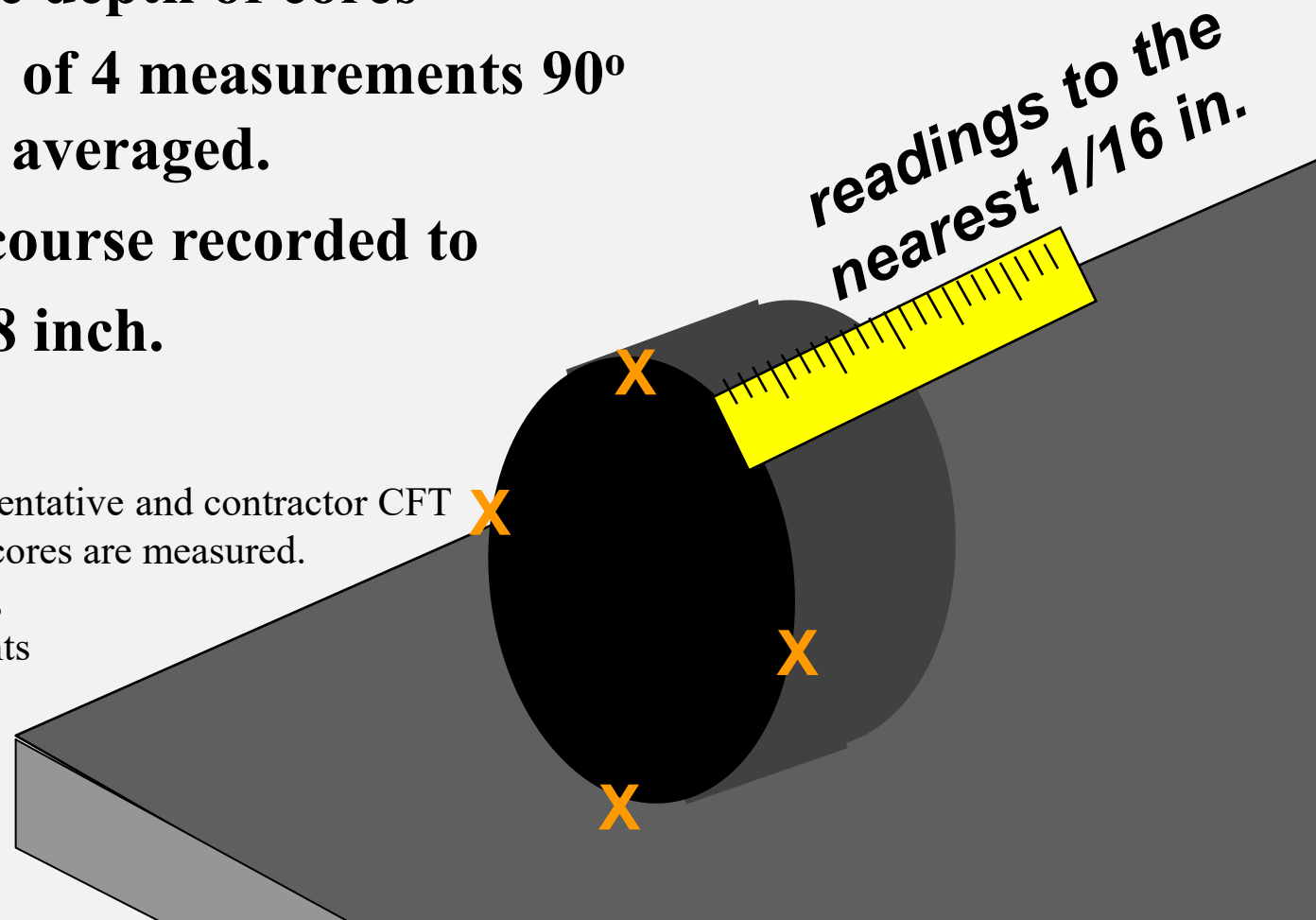

PTM 746
Sampling Asphalt Paving
Mixtures

PTM #746: Sampling Asphalt Paving Mixtures

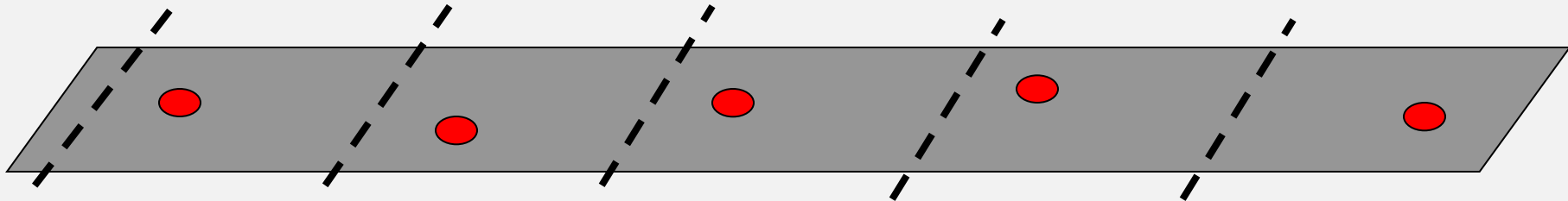

***Location of samples determined as described
in PTM 1: Probability Sampling***

PTM #746: Sampling Asphalt Paving Mixtures

- **Defines normal lot as 2,500 tons with 5 sublots of 500 tons.**
- **Defines sampling of projects with less than 2,500 tons total**
 - > 500 tons & < 2,500tons: total quantity divided into 5 sublots**
 - \leq 500 tons: total quantity divided into 3 sublots**

PTM #746: Sampling Asphalt Paving Mixtures

Acceptance Sampling on the Roadway

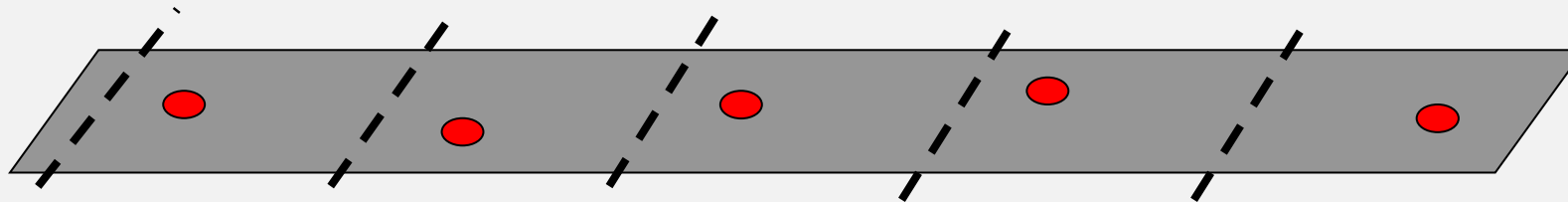

- **One sample from each subplot using PTM #1**
- **Equipment:**
 - Flat-bottom, high sided scoop
 - Boxes approximately 3 ³/₄” x 4 ³/₄” x 9 ¹/₂” (approximately 8 lbs of material)
 - Putty knife for scraping INSIDE of scoop
 - Incidental materials & equipment

PTM #746:

Sampling Asphalt Paving Mixtures

Acceptance Sampling on the Roadway

- Samples taken from uncompacted mix directly behind the paver
- Each sample has a Form TR-447 for proper ID and info.
- Proper # increment barcode sticker on outside box

PTM #746: Sampling Asphalt Paving Material

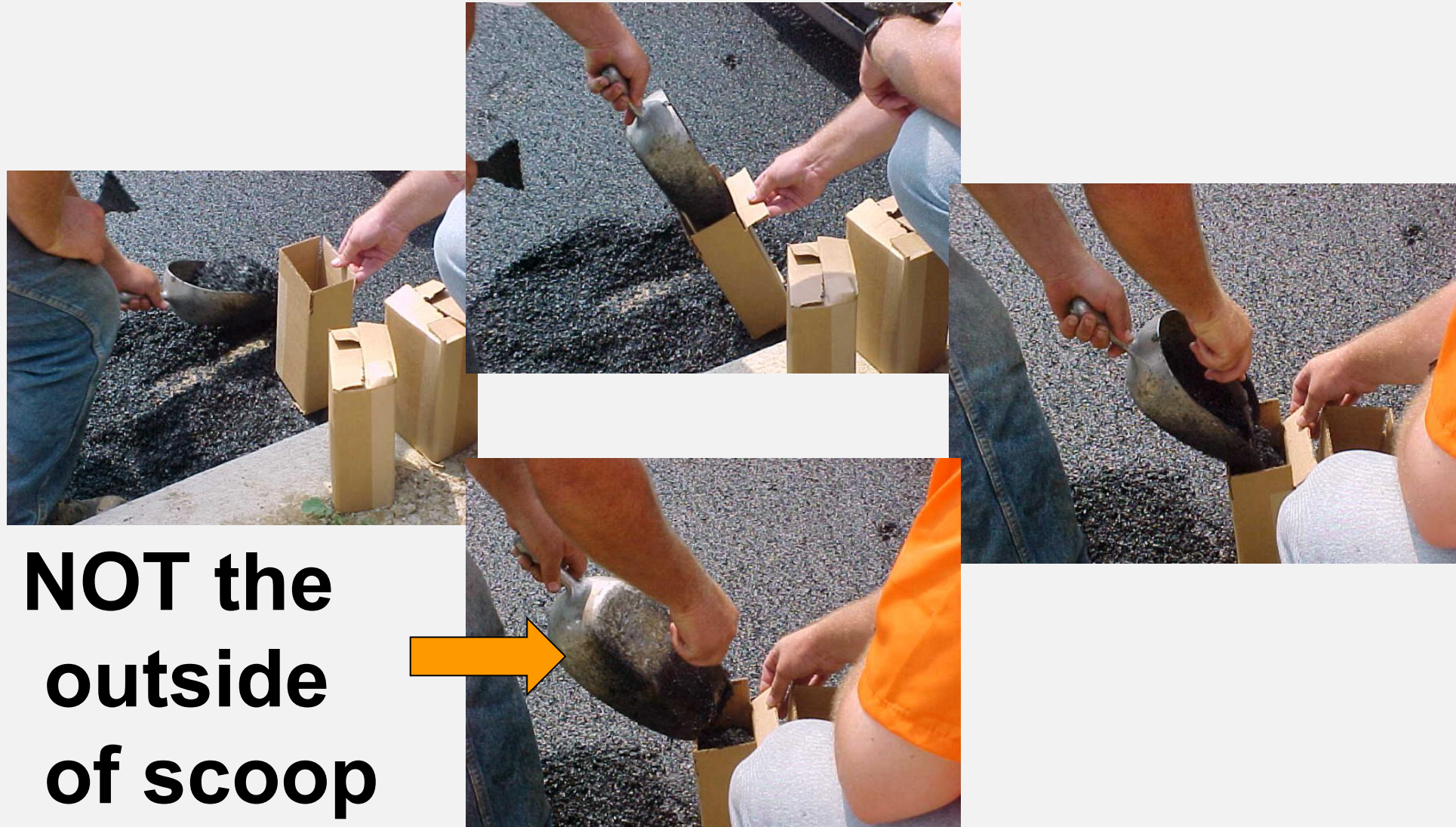

PTM #746: Sampling Asphalt Paving Mixtures

Acceptance Sampling on the Roadway

- Sampling scoop should pass completely through entire depth of material lift, transferring material to box, scraping any remaining fines from **INSIDE** scoop.
- **PTM Appendix provides examples for locating samples**
 - Example 1: Based on tonnage – addresses procedure with MTV
 - Example 2: Based on square yards

PTM #746: Sampling Asphalt Paving Mixtures

PTM also includes:

- Sampling at the production plant under a quality control program with appropriate illustrative example
- Quality assurance sampling from hauling units with appropriate illustrative example

PTM 746

- **Contains new information on selection of sample locations, equipment, procedures, identification and delivery, and illustrative examples for both plant and field.**

NOTE: Samples taken at a producer by use of time intervals will not directly correlate to lot/ subplot designations

PTM 746

- For large NMAS mixes, contractor may obtain larger size samples and then reduce in size. Here is the language in PTM 746.
- **Section 5.11:** for 3/4” (19 mm) and larger NMAS mixtures, a sample larger than is required in section 4.1 may be obtained and placed on a mixing board, thoroughly mixed, formed into a flat pile and carefully quartered to provide a representative sample of the required size. Scrape the inside of the scoop at each transfer point to incorporate any fines sticking to the inside of the scoop.

PTM 747

**Determination of Distributor
Application Rate in the Field**

PTM #747:

Determination of Distributor Application Rate in the Field

- Calibration of distributor prior to test required
- Equipment
 - 48” Carpenter’s level
 - Dipstick for tank
 - Manufacturer’s certificate of calibration
- Application rate of higher temperature materials determined by correcting temperature using Bulletin 25 conversion chart

PTM #747:

Determination of Distributor Application Rate in the Field

- **Procedure**

- Level tank with level on top of manhole
- Use dipstick to measure material level in tank, calculate gallons from calibration table
- Select test strip length according to Table 1

Table 1. Length of Test Strip	
App. Rate, gal/sq.yd.	Length of Test Strip, feet
Less than or = 0.01	1,000
More than 0.01	500

Note: Dipstick should agree with gauge and be marked with serial number of distributor unit Wheel or infra-red unit on truck should agree with measured distance

Application Rate Calculation for 60% Residue TACK or NTT/CNTT

Application Rate: (AR)

AR= required residue ÷ asphalt content as a decimal

Assume 0.03 gallons/sq. yd. is the required RESIDUE.

AR=0.03 ÷0.60 (60%) OR AR = 0.05 gallons/sq. yd.

Check: 0.05 applied X 0.60 asphalt content =0.03 gallons of residue per square yard

PTM #747:

Determination of Distributor Application Rate in the Field

- **Procedure (continued)**
 - Apply material to test strip
 - Level tank again and measure level of material with dipstick
 - Calculate application rate
 - Multiply length X width and divide by 9 to calculate square yards.
 - Divide gallons placed by square yards covered to determine Application rate.
 - Multiply Application rate by % of asphalt in tack to determine yield

Segregated or Flushed Pavement

- Inspector notifies contractor that segregation or flushing is suspected.
- Contractor may elect to proceed at their own risk from that point while trying to rectify the problem.
- **PTM 751** will be performed to evaluate the condition.

PTM #751: Measuring Surface Macrotexture Depth Using A Volumetric Technique & Determining Pattern Segregation

- Also known as **Hockey Puck Test**
- Used to determine degree of segregation or flushing
- Measures voids in pavement surface and indicates segregation or gradation change

PTM 751 PROCEDURES

- Areas must be clean and dry with no loose debris
- Test will be performed in 3 suspect and three acceptable locations
- A measured quantity of material is applied to mat surface and spread to largest possible diameter circle
- Difference in diameter is used to determine average surface texture depth

PTM 751 PROCEDURES

- Obtain the texture depth from each set of locations from Table 1 on page 7 of PTM 751
- If average texture depth difference exceeds 0.024 the area is considered “unacceptable pattern segregation”

If Unacceptable Pattern Segregation Is Evident (via PTM 751)

- **Stop Paving**
- **Department will evaluate segregation to determine corrective work**
 - DO NOT resume paving until Department reviews corrective actions & authorizes paving to continue
- **Test section then placed, <200 tons**
- **Resume normal paving after successful test section**

Evaluating Segregated Area

- **Evaluating Segregation [PennDOT Specs Section 413.3(h)3.c]:**
 - Take 6” Cores.
 - Remove & Replace Segregated Areas if sum of any 2 sieves vary 20% or more from the JMF or core Density is less than 90%.
 - Remove full lane width of segregated area plus 5 feet minimum beyond each end.

Summary

- **Reviewed Field Related Asphalt PTMs**
 - Probability Sampling
 - Sampling loose material
 - In-Place Density Measurement Techniques
 - Pavement Profile Measurement
 - Core Thickness Measurement
 - Distributor Application Rate
 - Measuring Surface Texture to identify pattern segregation